

Figure 38. Nose Landing Gear (D-4866 thru D-6561)

FIG. & INDEX NO.	PART NO.	DESCRIPTION							UNITS PER ASSY	USABLE ON CODE
		1	2	3	4	5	6	7		
38	35-825001	GEAR INSTL,NOSE LANDING	NP	1	
	35-825001-10	GEAR INSTL,NOSE LANDING	NP	2	
	35-825001-2	• GEAR ASSY,NOSE WHEEL.	1	1	
	35-825001-8	• GEAR ASSY,NOSE WHEEL.	1	2	
		/ATTACHING PARTS/								
- 1	AN6-23A	• BOLT.	2		
- 2	35-825029	• BUSHING,NOSE GEAR ATTACHING	2		
	AN960-616	• WASHER.	4		
	100951X032YP	• WASHER.	2		
	AN365-624	• NUT	2		

- 3	35-825175	• GUARD ASSY,NOSE WHEEL SCRAPER	1	3	
		/ATTACHING PARTS/								
- 4	AN525-10-6	• SCREW	1		
	AN960-10L	• WASHER.	1		
	MS20364-1032	• NUT	1		
- 5	AN4-5A	• BOLT.	1		
	AN960-416L	• WASHER.	1		
	AN365-428	• NUT	1		
	AN960-416	• WASHER.	1		
- 6	AN4H3A	• BOLT.	1		

	35-825100-6	• STRUT ASSY,NOSE WHEEL SHOCK	1	3	
		/SUPERSEDES 35-825100/								
- 7	35-825110-4	• BRACE ASSY,NOSE WHEEL TOP	1	3	
- 8	35-820111	• BEARING,NOSE WHEEL TOP BRACE.	2	3	
- 9	35-825112	• BEARING,NOSE WHEEL BRACE.	2	3	
- 10	105740X-ZU1365	• BUSHING	1	3	
- 11	35-820113	• BEARING,TOP BRACE RETRACT LUG	1	3	
- 12	105740X-YN1458	• BUSHING	1	3	
- 13	1728B	• FITTING,LUBRICATION /SUPERSEDES 1645/	4	3	
- 14	35-825090	• BARREL ASSY,NOSE WHEEL STRUT.	1	1	
	35-825090-10	• BARREL ASSY,NOSE WHEEL STRUT.	1	2	
	35-825125-602	• AXLE & PISTON ASSY,NOSE WHEEL STRUT	1	3	
		/SPARE ASSY,SEE ADDENDUM/								
- 15	35-825125	• AXLE & PISTON ASSY,NOSE WHEEL STRUT	NP	3	
- 16	35-825115	• CLIP,NOSE WHEEL SCRAPER	1	3	
		/ATTACHING PARTS/								
- 17	AN4-20A	• BOLT	1		
	AN960-416	• WASHER.	1		
	AN365-428	• NUT	1		

	35-825102-2	• CONTROL ASSY,NOSE WHEEL REBOUND	1	3	
		/SUPERSEDES 35-825102/								
		/ATTACHING PARTS/								
- 19	AN6227-5	• PACKING	1		
- 20	AN960-416	• WASHER.	1		
- 21	AN363-428	• NUT	1		

	35-825025-4	• ORIFICE ASSY,REBOUND CONTROL.	1	3	
	35-825030	• TUBE ASSY,REBOUND CONTROL	1	3	
- 22	35-825032	• PIN ASSY,REBOUND CONTROL.	1	3	
- 23	35-825100-4	• PAD,BARREL.	2	3	
- 24	35-825092	• CAP,BARREL.	1	3	
		/ATTACHING PARTS/								
- 25	AN960-10	• WASHER.	2		
- 26	AN960-A10L	• WASHER.	4		
- 27	AN365-1032	• NUT.	6		

- 28	35-825101	• SHIM,BARREL CAP	1	3	
	35-825024	• ROLLER ASSY,NOSE WHEEL STRAIGHTENING.	1	3	

FIG. & INDEX NO.	PART NO.	DESCRIPTION	UNITS PER ASSY	USABLE ON CODE
38 - 29	35-825024-2	BRACKET,ROLLER ASSY	1	3
- 30	AN505-4J	BEARING,NOSE WHEEL STRAIGHTENING. /ATTACHING PARTS/	1	3
- 31	AN24-13	BOLT	1	
	AN960-416	WASHER	1	
	AN310-4	NUT	1	
	AN380-2-2	PIN,COTTER	1	
- 32	AN6227-20	PACKING,ORIFICE	1	3
- 33	AN6227-24	PACKING,BARREL	1	3
- 34	AN6227-27	PACKING,GLAND	1	3
- 35	35-825100-2	PAD,PISTON	1	3
- 36	35-825153	RING,PISTON WIPER	1	3
- 37	111190-2	RING,PISTON SCRAPER	1	3
- 38	111200-2	RING,SNAP	1	3
- 39	35-825060	KNEE ASSY,NOSE WHEEL STRUT. /ATTACHING PARTS/	2	3
- 40	35-820027	PIN,TORQUE KNEE UPPER	1	
- 41	35-825106	PIN,TORQUE KNEE LOWER	1	
- 42	AN392-17	PIN,FLAT HEAD	2	
	AN380-2-1	PIN,COTTER	2	
- 43	AN4-12	BOLT	1	
	100951S063ZZ	WASHER	1	
- 44	35-820028	BUSHING,TORQUE KNEE GRIP	1	
	100951S063YH	WASHER	1	
	AN310-4	NUT	1	
	AN380-2-2	PIN,COTTER	1	
- 45	35-820062	BUSHING,TORQUE KNEE	2	3
- 46	1729	FITTING,LUBRICATION	3	3
- 47	35-825145	DAMPENER ASSY,SHIMMY /SEE FIG. 40/ /ATTACHING PARTS/	1	3
- 48	AN6-31A	BOLT	1	
	100951X063YN	WASHER	1	
- 49	1057395-YP1483	BUSHING	1	
	100951X031YM	WASHER	1	
	AN365-624	NUT	1	
- 50	AN3-6A	BOLT	1	
	AN960-10	WASHER	1	
- 51	1057395-ZK0190	BUSHING	1	
	AN960-10L	WASHER	1	
	AN365-1032	NUT	1	
- 52	35-825190	BODY,BLEEDER VALVE	1	2
- 53	AN6290-2	RING,O	1	2
- 54	302D	CORE,BLEEDER VALVE	1	3
- 55	AN813-1A	CAP,BLEEDER VALVE	1	3
- 56	35-825064	PLACARD,NOSE GEAR SHOCK STRUT MODEL	1	3
- 57	35-825189	PLACARD,NOSE WHEEL STRUT CAP	1	3
	35-825001-12	KIT ASSY,BALANCED WHEEL	1	4
	35-825001-14	KIT ASSY,BALANCED WHEEL /USE WITH TUBELESS TIRE/	1	4
- 58	2500X5	TIRE	1	5
	2500X5	TIRE,4 PLY TUBELESS /USED WITH P/N 9532102 OR 9532669/	1	4
- 59	2500X5	TUBE	1	5
- 60	35-825001-6	HOSE,NOSE WHEEL VALVE STEM	1	
	9520653	WHEEL ASSY,NOSE	1	5
	9532669	WHEEL ASSY,NOSE /ALTERNATE FOR 9520653/ /ATTACHING PARTS/	1	5
- 61	35-825129	WASHER,NOSE WHEEL AXLE	1	
- 62	AN7502-20	NUT	1	
	AN380-4-7	PIN,COTTER	1	

FIG. & INDEX NO.	PART NO.	DESCRIPTION							UNITS PER ASSY	USABLE ON CODE
		1	2	3	4	5	6	7		
38	9510186	1	5
		/ATTACHING PARTS/								
- 63	9520206	3	
- 64	NO NUMBER	6	
- 65	AN365-428	3	

- 66	9520651	1	5
- 67	08231	1	5
	9520925	1	5
- 68	9530355	1	5
- 69	08231	1	5
- 70	08125	2	5
- 71	9510236	4	5
- 72	510524-25	2	5
- 73	A-60151	2	5
	9532569	1	4
		/ATTACHING PARTS/								
	95-820000-1	1	
	95-820000-3	1	
	AN7502-20	REF	
	AN380-4-7	REF	

	9524193	1	4
	LM67010XL	1	4
	9524192	1	4
	LM67010XL	1	4
	LM67048XL	1	4
	AN6230820	1	4
	AN4-14A	3	4
	AN960-416	6	4
	22FH-428	3	4

CODE EFFECTIVITY

1 D-4866 THRU D-5725
 3 D-4866 THRU D-6561
 5 D-5726 THRU D-5985

CODE EFFECTIVITY

2 D-5726 THRU D-6561
 4 D-5986 THRU D-6561

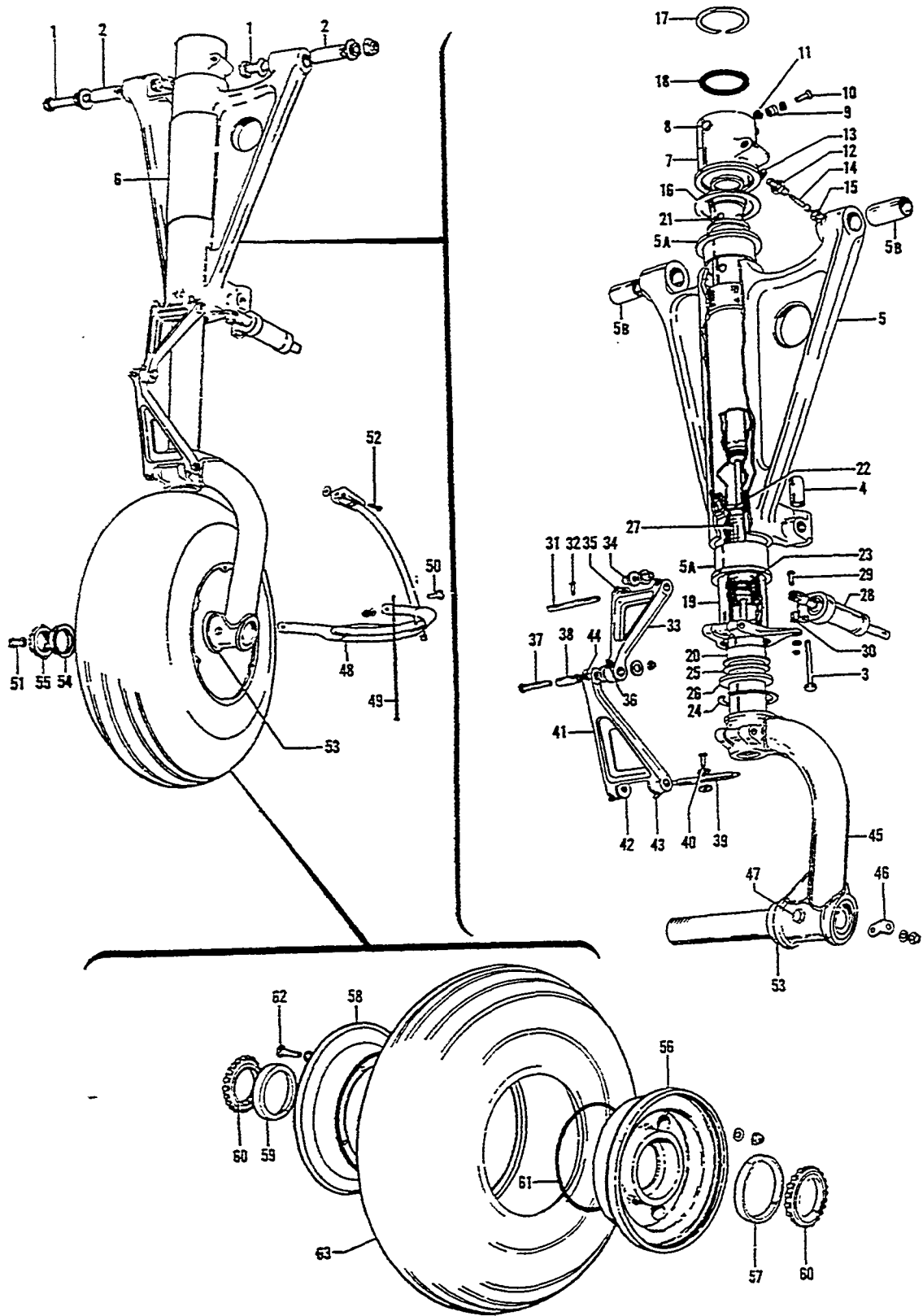

Figure 38A. Nose Landing Gear (D-6562 And After)

FIG. & INDEX NO.	PART NO.	DESCRIPTION	UNITS PER ASSY	USABLE ON CODE
38A-	35-825196-1	GEAR INSTL,NOSE /TUBELESS TIRE/	NP	8
	35-825196-11	GEAR INSTL,NOSE /TUBE TYPE TIRE/	NP	10
	35-825196-29	GEAR INSTL,NOSE /TUBE TYPE TIRE/	NP	9
	35-825196-27	GEAR INSTL,NOSE /TUBELESS TIRE/	NP	9
	35-825196-616	. GEAR ASSY,NOSE	1	15
	35-825196-620	. GEAR ASSY,NCSE	1	4
	35-825196-615	. GEAR ASSY,NOSE	1	14
	□35-825196-691	. GEAR ASSY,NOSE /LESS WHEEL ASSY/	1	11
	35-825196-695	. GEAR ASSY,NOSE /LESS WHEEL ASSY/	1	12
	35-825196-605	. GEAR ASSY,NOSE,/WITH WHEEL ASSY/	1	13
	35-825195	. . ABSORBER ASSY,DIRECT ACTION SHOCK	1	8
	35-825195-55	. . ABSORBER ASSY,DIRECT ACTION SHOCK	1	9
		/ATTACHING PARTS/		
- 1	□NAS146-46	. . BOLT	2	
- 2	□45-825011	. . BUSHING,NOSE GEAR GRIP	2	
	□100951X032YP	. . WASHER	4	
	□100951S016YP	. . WASHER,/ALTERNATE FOR 100951X032YP/	AR	
	□AN960-616	. . WASHER	2	
	□NAS143-6C	. . WASHER /SUPERSEDES MS20002C6/	2	
	□MS20365-624	. . NUT /SUPERSEDES AN365-624/	2	
	□95-824005-601	. . . BRACE ASSY,NOSE LANDING GEAR	1	1
		/ATTACHING PARTS/		
- 3	□AN6-31A/M/	. . . BOLT	1	
- 4	□1057395-YP1483	. . . BUSHING	1	
	100951X032YM	. . . WASHER	1	
	□MS20365-624	. . . NUT /SUPERSEDES AN365-624/	1	
- 5	□95-824005-1	. . . BRACE,NOSE LANDING GEAR	1	1
- 5A	□35-820115	. . . BEARING,BARREL	2	1
- 5B	□35-820135	. . . BEARING,PIVOT	2	1
- 6	□35-825197	. . . PLATE,NOSE GEAR SHOCK ABSORBER	1	1
		INSTRUCTIONS		
- 7	□45-825033	. . . COLLAR,NOSE GEAR STEERING	1	1
		/ATTACHING PARTS/		
- 8	□45-825034	. . . BOLT,NOSE GEAR COLLAR ATTACHING	2	
- 9	□NAS505-4J	. . . BEARING,NEEDLE	1	1
- 10	□NAS222-16	. . . SCREW	1	1
	□AN960-416	. . . WASHER	2	
- 11	□S1452-048	. . . NUT,BARREL	1	1
- 12	□35-820125	. . . BODY,NOSE STRUT FILLER VALVE	1	2
	□118642-1	. . . BODY,NOSE STRUT FILLER VALVE	1	3
- 13	AN6227-6	. . . RING,NOSE STRUT FILLER VALVE O.	1	2
	□MS28778-5	. . . PACKING,NOSE STRUT FILLER VALVE	1	3
- 14	□302D	. . . CORE,NOSE STRUT FILLER VALVE	1	1
- 15	□AN813-1B	. . . CAP,NOSE STRUT FILLER VALVE	1	1
- 16	□35-820134	. . . SHIM,NOSE WHEEL STEERING COLLAR	1	1
- 17	□NAS50-187	. . . RING,INTERNAL RETAINER	1	1
- 18	AN6230-1	. . . RING,O.	1	1
	□35-825195-21	. . . BARREL ASSY,SHOCK ABSORBER	1	2
	□35-825195-31	. . . BARREL ASSY,SHOCK ABSORBER	1	3
- 19	□35-825195-27	. . . BRAZE ASSY,SHOCK ABSORBER BARREL	1	2
	35-825195-33	. . . BRAZE ASSY,SHOCK ABSORBER BARREL	1	3
	35-825195-33	. . . BRAZE ASSY,SHOCK ABSORBER BARREL	1	3
- 20	□45-825031	. . . BEARING,LOWER PISTON NOSE GEAR	1	1
	35-825195-15	. . . TUBE ASSY,SHOCK ABSORBER ORIFICE	1	1
- 21	35-825195-13	. . . TUBE,SHOCK ABSORBER ORIFICE	1	1
- 22	AN6230-2	. . . RING,O.	1	1
- 23	□35-380020-3	. . . RING,SHOCK ABSORBER PISTON	1	1
- 24	□111200-6	. . . RING,SNAP	1	1
- 25	□45-825032	. . . ADAPTER,NOSE GEAR PISTON SCRAPER	1	1
- 26	□AN6231A19	. . . SCRAPER,NOSE GEAR PISTON	1	1
- 27	□35-820130-2	. . . PAD,SHOCK ABSORBER	1	1
- 28	□35-825145	. . . DAMPENER ASSY,NOSE GEAR SHIMMY	1	1
		/SEE FIG. 40/		
		/ATTACHING PARTS/		
- 29	□AN3-6A/M/	. . . BOLT	1	
- 30	□1057395-ZK0190	. . . BUSHING	1	
	□AN960-10	. . . WASHER	1	
	□AN960-10L	. . . WASHER	1	
	□MS20365-1032	. . . NUT /SUPERSEDES AN365-1032/	1	

FIG. & INDEX NO.	PART NO.	DESCRIPTION	UNITS PER ASSY	USABLE ON CODE
38A-	□35-820107	• • KNEE ASSY,NOSE SHOCK ABSORBER UPPER TORQUE. /ATTACHING PARTS/	1	1
- 31	□35-820108	• • • PIN,TORQUE KNEE	1	8
	35-825200	• • • PIN,TORQUE KNEE	1	9
- 32	□AN392-23	• • • PIN	1	
	□AN380-2-1	• • • PIN,COTTER.	1	
- 33	□35-820107-5	• • • KNEE,NOSE SHOCK ABSORBER UPPER TORQUE . /SUPERSEDES 35-820107-3/	1	1
- 34	□35-820123	• • • BUSHING,UPPER KNEE.	2	1
- 35	□MS15002-1	• • • FITTING,LUBRICATION	2	1
- 36	□1729	• • • FITTING,LUBRICATION	1	1
- 37	□AN4-12/M/	• • • BOLT.	1	
- 38	□35-820028	• • • BUSHING,NOSE WHEEL TORQUE KNEE GRIP	1	1
	□100951S063ZZ	• • • WASHER.	1	
	□100951S063YH	• • • WASHER.	1	
	□AN310-4/M/	• • • NUT	1	1
	□AN380-2-2	• • • PIN,COTTER.	1	1
	□35-825193	• • • KNEE ASSY,NOSE GEAR LOWER TORQUE. /ATTACHING PARTS/	1	1
- 39	□35-820132	• • • PIN,NOSE WHEEL LOWER TORQUE KNEE.	1	
- 40	□AN392-21	• • • PIM	1	
	□AN960-616	• • • WASHER.	2	
	□AN380-2-1	• • • PIN,COTTER.	1	
- 41	□35-825193-1	• • • KNEE,NOSE GEAR LOWER TORQUE	1	1
- 42	□35-820123	• • • BUSHING,LOWER KNEE.	2	1
- 43	□MS15002-1	• • • FITTING,LUBRICATION	2	1
- 44	□1729	• • • FITTING,LUBRICATION	1	1
- 45	□35-825195-601	• • • STRUT ASSY,SHOCK ABSORBER LOWER /WELDED/.	1	11
	□35-825195-603	• • • STRUT ASSY,SHOCK ABSORBER LOWER /FORGED/.	1	12
- 46	□35-820133	• • • CLIP,NOSE WHEEL SCRAPER ATTACHING /ATTACHING PARTS/	1	1
- 47	□AN4-21A/M/	• • • BOLT.	1	
	□AN960-416	• • • WASHER.	1	
	□MS20365-428	• • • NUT /SUPERSEDES AN365-428/.	1	
- 48	□35-825175-12	• • GUARD ASSY,NOSE WHEEL SCRAPER /SUPERSEDES 35-825175-6/	1	1
- 49	□35-825196-25	• • CABLE ASSY,GROUND /SUPERSEDES 45-361235/. . /ATTACHING PARTS/	1	1
- 50	□96-810013	• • BOLT,LH SIDE /SUPERSEDES 96-820011/	1	
- 51	□AN4H3A/M/	• • BOLT,RH SIDE.	1	
- 52	□AN4H4A/M/	• • BOLT.	1	
	□AN960-416	• • WASHER.	6	
	□MS20365-428	• • NUT,LH SIDE /SUPERSEDES AN365-428/. . . .	1	7
	□MS20364-428	• • NUT,LH SIDE /SUPERSEDES AN364-428/. . . .	1	6
	35-825001-14	• • KIT,BALANCED WHEEL ASSY /TUBELESS/.	1	1
	35-825196-17	• • WHEEL ASSY,BALANCED /TUBE TYPE/ /ATTACHING PARTS/	1	5
- 53	□35-825195-35	• • WASHER,NOSE WHEEL AXLE. /SUPERSEDES 95-820000-1/	1	
- 54	□95-820000-3	• • WASHER,NOSE WHEEL AXLE.	1	
- 55	□AN7502-20	• • NUT,WHEEL BEARING RETAINING	1	
	□AN380-4-7	• • PIN,COTTER.	1	
	□9532669	• • • WHEEL ASSY,NOSE /SUPERSEDES 9532102/. . . .	1	1
	□9532926	• • • WHEEL ASSY,NOSE	1	5
- 56	□95-32671	• • • SUB ASSY,NOSE WHEEL LH. /SUPERSEDES 9524193/	1	1
	□9541899	• • • SUB ASSY,NOSE WHEEL LH.	1	5
- 57	□LM67010XL	• • • CUP,NOSE WHEEL BEARING.	1	1
	9525676	• • • PLATE,DATA.	1	5

FIG. & INDEX NO.	PART NO.	1	2	3	4	5	6	7	DESCRIPTION	UNITS PER ASSY	USABLE ON CODE
38A- 58	□9524192	SUB ASSY,NOSE WHEEL RH.	1	1
	□9541898	SUB ASSY,NOSE WHEEL RH.	1	5
- 59	□LM67010XL	CUP,NOSE WHEEL BEARING.	1	1
	9525675	PLATE,DATA.	1	5
- 60	□LM67048XL	CONE,NOSE WHEEL BEARING	2	1
- 61	□AN6230B20	SEAL,NOSE WHEEL O RING.	1	1
- 62	□AN4-14A/M/	BOLT,NOSE WHEEL	3	1
	□AN960-416	WASHER.	6	1
	□AN960-516L	WASHER.	1	5
	□MS20365-428C	NUT,FLEX LOC /SUPERSEDES. 22FH428/	3	1
	9534587	BUSHING,VALVE STEM.	1	5
- 63	□5.00X5 4PTT	TIRE,FOUR PLY TUBE TYPE	1	5
	□5.00X5	TUBE,TIRE	1	5
	□5.00X5 4PTT	TIRE,FOUR PLY SIDE VALVE TUBELESS	1	1

CODE EFFECTIVITY

- 1 D-6562 AND AFTER
- 3 D-6992 AND AFTER
- 5 D-7662 AND AFTER
- 7 D-6562 THRU D-7309
- 9 D-8599 AND AFTER
- 11 D-6562 THRU D-7251
- 13 D-6562 THRU D-7280
- 15 D-7654 THRU D-8598

CODE EFFECTIVITY

- 2 D-6562 THRU D-6991
- 4 D-8599 AND AFTER
- 6 D-7310 AND AFTER
- 8 D-6562 THRU D-8598
- 10 D-7662 THRU D-8598
- 12 D-7252 AND AFTER
- 14 D-7281 THRU D-7653