

Honeywell

INSTALLATION MANUAL

BENDIX/KING[®]

KLN 94

GPS NAVIGATION SYSTEM

MANUAL NUMBER 006-10599-0004

REVISION 4 JANUARY, 2003

WARNING

Prior to export of this document, review for export license requirement is needed.

COPYRIGHT NOTICE
2000, 2003 Honeywell International, Inc.

Reproduction of this publication or any portion thereof by any means without the expressed written permission of Honeywell is prohibited. For further information contact the Manager of Technical Publications, Honeywell, Olathe, KS 66061. Telephone: (913) 782-0400

REVISION INSTRUCTIONS AND HISTORY

MANUAL KLN 94 GPS NAVIGATION SYSTEM INSTALLATION
REVISION 2
PART NUMBER 006-10599-0002

Where R & R appears in the action column, remove the page now in the installation manual and replace it with the enclosed page; otherwise, ADD or DESTROY pages as listed. Retain these instructions in the front of the installation manual as a Record of Revisions.

PAGE	ACTION	REASON FOR CHANGE
KLN 94 IM Covers	R&R	Updated
Revision History	ADD	Updated
1-1 thru 1-6	R&R	Updated
1-9 thru 1-10	R&R	Corrected
2-5 thru 2-12	R&R	Updated
2-23 thru 2-82	R&R	Updated

REVISION INSTRUCTIONS AND HISTORY

MANUAL KLN 94 GPS NAVIGATION SYSTEM INSTALLATION
REVISION 4
PART NUMBER 006-10599-0004

Where R & R appears in the action column, remove the page now in the installation manual and replace it with the enclosed page; otherwise, ADD or DESTROY pages as listed. Retain these instructions in the front of the installation manual as a Record of Revisions.

PAGE	ACTION	REASON FOR CHANGE
KLN 94 IM Covers	R&R	Updated
Revision History	R&R	Updated
1-5 thru 1-6	R&R	Revised
2-78 thru 2-79	R&R	Revised

THIS PAGE IS RESERVED

SECTION I
GENERAL INFORMATION

Paragraph	Page
1.1 INTRODUCTION	1-1
1.2 EQUIPMENT DESCRIPTION	1-1
1.3 TECHNICAL CHARACTERISTICS	1-1
1.3.1 KLN 94 Technical Characteristics	1-1
1.3.2 KA 91 Antenna Technical Characteristics	1-5
1.3.3 KA 92 Antenna Technical Characteristics	1-5
1.3.4 KA 198 Comm Filter Technical Characteristics	1-5
1.4 UNITS AND ACCESSORIES SUPPLIED	1-6
1.4.1 KLN 94 GPS Receiver	1-6
1.4.2 GPS Antenna	1-6
1.4.3 KLN 94 Installation Kit	1-6
1.4.4 KA 91/92 Installation Kit	1-7
1.4.5 Database	1-8
1.5 ACCESSORIES REQUIRED, BUT NOT SUPPLIED	1-8
1.5.1 Forced Air Cooling	1-8
1.5.2 Indicators and HSIs	1-9
1.5.3 CDI Indicator With “MSG” and “WPT” Annunciators	1-9
1.6 OPTIONAL ACCESSORIES	1-9
1.6.1 PC Interface Kit	1-9
1.6.2 Annunciators and Switch / Annunciators	1-10
1.6.3 NAV / GPS Switching	1-13
1.6.4 Right Angle Connector	1-13
1.7 LICENSE REQUIREMENTS	1-13
1.8 RECOMMENDATIONS FOR IFR APPROVAL	1-13
1.8.1 Aircraft Logbook Entry	1-13
1.8.2 Aircraft Installation Requirements	1-13
1.8.3 Approved Airplane Flight Manual Supplement	1-14
1.8.4 Pilot’s Guide	1-14
1.9 INSTRUCTIONS FOR CONTINUED AIRWORTHINESS	1-14

SECTION II
INSTALLATION

Paragraph	Page
2.1 GENERAL INFORMATION	2-1
2.2 UNPACKING AND INSPECTING EQUIPMENT	2-1
2.3 EQUIPMENT INSTALLATION	2-1
2.3.1 Avionics Cooling Requirements For Panel Mounted Equip.	2-1
2.3.2 KLN 94 Mechanical Installation	2-2
2.3.3 Antenna Selection	2-2
2.3.4 Antenna Installation Considerations	2-2
2.3.5 Antenna Mechanical Installation	2-3
2.3.6 Electrical Installation	2-4
2.4 POST INSTALLATION CHECK OUT INFORMATION	2-67
2.4.1 Maintenance Pages	2-67
2.4.2 Post Installation Checkout Procedure	2-73
2.4.3 Installation Check Out	2-74
2.4.4 Integrated Installation Check Out	2-75
2.5 ERROR CODES	2-80

SECTION III
OPERATION

Paragraph	Page
3.1 GENERAL INFORMATION	3-1

APPENDIXES

APPENDIX A - RS 232 FORMAT DEFINITION	A-1
APPENDIX B - SUPPLEMENTALS	B-1
APPENDIX C - SUPPLEMENTAL TYPE CERTIFICATE	C-1
APPENDIX D - DIRECT REPLACEMENT OF A KLN-89B WITH A KLN-94	D-1
APPENDIX E - ENVIRONMENTAL QUALIFICATION FORMS	E-1

LIST OF ILLUSTRATIONS

Figure		Page
2-1	KLN 94 P941 CONNECTOR PIN FUNCTIONS	2-10
2-2	KLN 94 P942 CONNECTOR PIN FUNCTIONS	2-11
2-3	KLN 94 P943 CONNECTOR PIN FUNCTIONS	2-13
2-4	KLN 94 CRIMPING AND INSERTION/EXTRACTION TOOLS	2-14
2-5	KLN 94 INSTALLATION DRAWING	2-15
2-6	KA 91 OUTLINE DRAWING	2-17
2-7	KA 91 INSTALLATION DRAWING	2-19
2-8	KA 91 BACKPLATE OUTLINE DRAWING	2-21
2-9	KA 92 OUTLINE DRAWING	2-23
2-10	KA 92 INSTALLATION DRAWING	2-27
2-11	KA 92 BACKPLATE OUTLINE DRAWING	2-29
2-12	KA 91/92 TNC ANTENNA COAX/CONNECTOR ASSEMBLY (0-40FT)	2-31
2-13	KA 91/92 BMA ANTENNA COAX/CONNECTOR ASSEMBLY	2-33
2-14	KA 91/92 TNC/BMA ANTENNA COAX/CONNECTOR ASSEMBLY (0-80FT) ..	2-35
2-15	KA 33 P/N 071-4037-00/01 FINAL ASSEMBLY	2-37
2-16	KA 33 P/N 071-4037-00/01 OUTLINE AND MOUNTING DRAWING	2-39
2-17	CUTLER-HAMMER SWITCH/ANNUN. MOUNTING DRAWING	2-41
2-18	CUTLER-HAMMER SWITCH/ANNUN. INTERNAL SCHEMATIC	2-43
2-19	KLN 94 SERIAL RECEIVERS & TRANSMITTERS INTERCONNECT DWG. ..	2-47
2-20	KLN 94 ALTITUDE AND RMI / OBI INTERCONNECT DRAWING	2-49
2-21	KLN 94 DEVIATION AND FLAGS INTERCONNECT DRAWING	2-51
2-22	KLN 94 OBS RESOLVER INTERCONNECT DRAWING	2-53
2-23	KLN 94 INTERCONNECT DRAWING	2-55
2-24	KLN 94 FCS & EXTERNAL ANNUNCIATOR INTERCONNECT DRAWING	2-57
2-25	KLN 94 BACKLIGHTING & ALT. ALERTING INTERCONNECT DRAWING	2-59
2-26	KLN 94 PC LOADER AND ANTENNA INTERCONNECT DRAWING	2-61
2-27	KLN 94 DATA LOADER/PC INTERFACE	2-63
2-28	KLN 94 QUICKTUNE INTERCONNECT DRAWING	2-65

LIST OF TABLES

Table		Page
2-1	GPS RECEIVER ERROR CODES.....	2-81
2-2	GPS PAGE MESSAGES	2-83
2-3	GPS SYSTEM ERROR CODES	2-84

THIS PAGE IS RESERVED.

SECTION I GENERAL INFORMATION

1.1 INTRODUCTION

This manual contains information relative to the physical, mechanical, and electrical characteristics of the BENDIX/KING KLN 94 Global Positioning System (GPS) Receiver. General installation procedures are also included.

1.2 EQUIPMENT DESCRIPTION

The KLN 94 is a panel mounted, long range, GPS based airborne navigation system with a database. The KLN 94 also provides VFR, IFR enroute, and IFR non-precision approach functions. The primary purpose of the equipment is to provide the pilot with present position information and to display guidance information with respect to a flight plan defined by the pilot. Flight plan information is entered by the pilot via various knobs and buttons on the front panel.

The unit can use its present position information to determine crosstrack error, distance to waypoint, ground speed, track angle, time to waypoint, bearing to waypoint, and advisory VNAV guidance. The database of the KLN 94 contains information concerning airports, VORs, NDBs, intersections, DP/STARs, outer markers, roads, rivers, railroads, lakes, etc., throughout the database's coverage area. Waypoints are stored in the database by their ICAO identifiers. The ICAO identifiers are in most cases taken directly from Jeppesen Sanderson or government aeronautical charts. The KLN 94 has instrument approach capabilities.

The information stored in the database eventually becomes out of date; therefore, to provide a means of updating the information, the database is housed in a data card which plugs into the front of the KLN 94. It is designed so that the user may easily remove the old database and install a current database. A secondary method of updating the database is by loading the information via an IBM compatible laptop computer. For more information on availability and cost of updating the database of the KLN 94, refer to the KLN 94 Pilot's Guide P/N 006-18207-0000.

1.3 TECHNICAL CHARACTERISTICS

1.3.1 KLN 94 TECHNICAL CHARACTERISTICS

TSO/JTSO Compliance:	TSO-C129a, JTSO-C129a - See Appendix C for environmental qualification.
Physical Dimensions:	Refer to KLN 94 installation drawing, Figure 2-5
Mounting:	Panel mounted with Honeywell supplied mounting rack
Cooling Requirements:	4 CFM (cubic feet per minute) provided by blower motor such as KA33 or equivalent.
Temperature Range:	-20°C to +55°C
Altitude Range:	Up to 55,000 Feet

Power Inputs:	11 to 33 VDC at 3.0 A Max. (-20°C to +55°C) 13.75 VDC @ 2.5 A Nominal 27.5 VDC @ 1.25 A Nominal
Panel Lighting Current Requirements:	
14 VDC Lighting:	220 mA Maximum
28 VDC Lighting:	110 mA Maximum
SIGNAL INPUTS	
GPS DISPLAYED:	
OPEN:	GPS displayed (when an indicator resolver is connected to the OBS resolver inputs)
GND	GPS not displayed (when an indicator resolver is not connected)
<u>TAKE HOME:</u>	
OPEN:	Normal Operation
GND:	Take Home Mode
<u>SPARE IN 0:</u>	These are reserved pins for future use.
<u>SPARE IN 1:</u>	
<u>SPARE IN 2:</u>	
<u>SPARE IN 3:</u>	
<u>TEST:</u>	
OPEN:	Normal Operation
GND:	Test Mode
<u>APPROACH ARM IN:</u>	This pin is normally open with a momentary low while the panel button is pressed.
DATA LOADER RS 232 IN:	This RS 232 input is designated to communicate with devices, ie. air data and fuel flow sensors via RS 232 format. (refer to RS 232 Format Definitions Appendix)
SPARE RS 232 IN:	This RS 232 input is reserved for future use.
GRAY CODE INPUTS: (A1, A2, A4, B1, B2, B4, C1, C2, C4, D4)	Gray Code Altitude Signals. (0 to 28 VDC) These inputs are diode isolated inside the KLN 94.
OBS SIN:	OBS resolver sine. Nominal input impedance is 33.8 K ohms (AC) and 100 K ohms (DC)

OBS COS:	OBS resolver cosine. Nominal input impedance is 33.8 K ohms (AC) and 100 K ohms (DC).
A/C POWER MONITOR:	This pin senses the aircraft power bus voltage. This high impedance input operates from 0 to 33 V with accuracy of 0.1 V.
CONFIGURATION MODULE:	Refer to Section 2.3.6.2
SIGNAL OUTPUTS:	
OBI SYNC, OBI CLOCK, & OBI DATA:	Honeywell Serial Data containing bearing to the active waypoint.
DATA LOADER/QUICKTUNETM RS 232 OUT:	The Data Loader/QuickTune RS 232 output is designed to communicate with an IBM compatible personal computer.
GENERAL RS 232 OUT:	The RS 232 output is designed to interface with certain ARNAV ELTs and certain moving map displays, and Shadin fuel flow systems (refer to RS 232 Format Definitions Appendix).
GPS SENSOR RS 232 OUT:	The GPS Sensor RS 232 output is a buffered connection to the GPS sensor (Xpress) transmitter connection to the host processor. It is designed to interface with a EGPWS, and for testing.
<u>WAYPOINT ANNUNCIATE:</u>	OPEN = Inactive LOW = Active (Output can sink up to 250 mA)
<u>MESSAGE ANNUNCIATE:</u>	OPEN = Inactive LOW = Active (Output can sink up to 250 mA)
<u>APPROACH ACTIVE ANNUNCIATE:</u>	OPEN = Inactive LOW = Active (Output can sink up to 250 mA)
<u>APPROACH ARM ANNUNCIATE:</u>	OPEN = Inactive LOW = Active (Output can sink up to 250 mA)
<u>SPARE ANNUNCIATE 1:</u>	Spare annunciators are reserved for future use.
<u>SPARE ANNUNCIATE 2:</u>	Spare annunciators are reserved for future use.
ROLL STEERING VALID N/A on -0101	Valid = ≥ 18 V in 28 VDC installations; ≥ 10 V in 14 VDC installations. Invalid = ≤ 3.5 V in all installations while sinking 1 mA. Output can source at least 250 mA.
ROLL STEERING HI N/A on -0101	Output Range: 550mV per degree of Bank. 2V per degree per second of Turn Rate.

ROLL STEERING LO	This is an output. It is always grounded
FCS LOC ENG:	OPEN = Inactive LOW = Active (Output can sink up to 250 mA)
LATERAL DEV FLAG +: LATERAL DEV FLAG -:	Valid: 350 to 900 mV (high) Flag in view: ≤ 50 mV (low) Output is capable of driving five 1k ohm parallel loads.
VERTICAL DEV FLAG +: VERTICAL DEV FLAG -:	Reserved for future use.
LATERAL SUPERFLAG:	Valid = ≥ 18 V in 28 VDC installations; ≥ 10 V in 14 VDC installations. Invalid = ≤ 3.5 V in all installations while sinking 1 mA. Output can source at least 250 mA.
VERTICAL SUPERFLAG:	Reserved for future use.
LATERAL DEV +L: LATERAL DEV +R-:	These outputs are differential pairs (+L and +UP are positive). Output range is ± 300 mV and is capable of driving five 1k ohm parallel loads.
VERTICAL DEV +UP: VERTICAL DEV +DOWN:	Reserved for future use.
OBS OUT:	Used to excite the OBS resolver rotor. Nominal output frequency = 450 Hz. Nominal unloaded peak amplitude = 6 V. Output drive capability = 40 mA.
+TO / +FROM Flag Outputs: To Indication: From Indication:	 +100 to +900 mV on +TO with respect to +FROM when desired course is within $\pm 85^\circ$ of the bearing to the active waypoint. -100 to -900 mV on +TO with respect to +FROM when desired course is within $180 \pm 85^\circ$ with respect to the bearing of the active waypoint. Outputs are capable of driving up to five 200 ohm parallel loads.
ALTITUDE ALERT ANNUNCIATE:	HIGH = Inactive LOW = Active (can sink up to 250 mA)
ALT ALERT AUDIO:	This output is active whenever ALTITUDE ALERT ANNUNCIATE is active, Signal is 1Khz, 3.5 Vrms max into 500 ohms. Refer to Paragraph 2.4.4.9 for the procedure to adjust the volume.

1.3.2 KA 91 ANTENNA TECHNICAL CHARACTERISTICS

TSO Compliance:	TSO-C129 - See Appendix C for environmental qualification.
Physical Dimensions:	Refer to KA 91 installation drawing, Figure 2-7
Airspeed Rating:	600 Kts. TAS
Output Impedance:	50 Ohms (nominal)
DC Voltage:	5 Volts \pm 0.5 Volt
DC Current:	50 mA (maximum)

1.3.3 KA 92 ANTENNA TECHNICAL CHARACTERISTICS

TSO Compliance:	TSO-C129 - See Appendix C for environmental qualification.
Physical Dimensions:	Refer to KA 92 installation drawing, Figure 2-10
Airspeed Rating:	600 Kts. TAS
Output Impedance:	50 Ohms (nominal)
DC Voltage:	5 Volts \pm 0.5 Volt
DC Current:	50 mA (maximum)

1.3.4 KA 198 COMM FILTER TECHNICAL CHARACTERISTICS (P/N 071-01565-0000)

Center Notch Frequency:	1575.42 MHz
Attenuation at 1575.42 \pm 1.5 MHz	35 dB (minimum)
Insertion Loss from 118.00 to 137.00 MHz	.3dB (maximum)
Impedance from 118.00 to 137.00 MHz	50 ohms
VSWR from 118.00 to 137.00 MHz	1.5:1

NOTE

The conditions and tests performed on this article are minimum performance standards. It is the responsibility of those desiring to install this article either on or within a specific type or class of aircraft to determine that the aircraft installation conditions are within these performance standards. The article may be installed only if further evaluation by the applicant documents an acceptable installation and is approved by the Administrator.

1.4 UNITS AND ACCESSORIES SUPPLIED

1.4.1 KLN 94 GPS RECEIVER

The KLN 94 is available in the following versions

PART NUMBER	14V / 28V LAMPS	BLACK BEZEL	CERTIFICATION	VERSION
069-01034-0101	X	X	VFR / IFR (BRNAV)	KLN 94
069-01034-0102	X	X	VFR / IFR (BRNAV and DC Roll Steering)	KLN 94

1.4.2 GPS ANTENNA

The KA 91 antenna is available by ordering P/N 071-01545-0200. The KA 92 antenna is available by ordering P/N 071-01553-0200.

1.4.3 KLN 89/89B/94 INSTALLATION KIT

The KLN 89/89B/94 Installation Kit (P/N 050-03321-0000) is available with crimp connectors only. A list of the required crimp tools and insertion/ extraction tools can be found in Section 2 of this manual. The kit and a complete list of the items contained in the kit is given below.

P/N	DESCRIPTION	UM	-0000	VENDOR NAME & P/N
030-01173-0000	CONN SUB-D HSG 25S (FEMALE PINS)	EA	1	
030-01175-0000	CONN SUB-D HGS 37S (FEMALE PINS)	EA	1	
073-01030-0502	CONNECTOR MOUNTING BRACKET	EA	1	
076-03019-0002	SHOULDER SCREW 4-40 W/FIN	RF	4	
089-05903-0004	SCR PHP 4-40 x 1/4	RF	4	
030-01157-0011	SOCKET CRMP 20G	EA	62	
089-05907-0004	SCR PHP 6-32 x 1/4	EA	4	
089-02353-0001	NUT CLIP 6-32	EA	6	
089-05903-0007	SCR PHP 4-40 x 7/16	EA	2	
089-06012-0006	SCR PHP 6-32 x 3/8	EA	6	
090-00019-0007	RING RTNR .438	EA	1	
030-00101-0002	PANEL MOUNT PLUG	EA	1	
187-01352-0000	GASKET	EA	1	

P/N	DESCRIPTION	UM	-0000	VENDOR NAME & P/N
047-05959-0002	STRAIN RELIEF W/H	EA	2	
047-05960-0001	STRAIN RELIEF W/F	EA	2	
200-08334-0000	EXT EEPROM BD	EA	1	
033-00230-0000	TELEPHONE JACK, 4 CONDUCTOR	EA	1	
057-05621-0000	DECAL DATA LOADER	EA	1	
057-05628-0000	GPS DISCLAIMER	EA	1	
089-08252-0030	WASHER	EA	1	

1.4.4 KA 91/92 INSTALLATION KIT

The KA 91 Installation Kit (P/N 050-03195-0000), including its contents, is shown below.

P/N	DESCRIPTION	UM	-0000	VENDOR NAME & P/N
050-03195-0000	KA 91 INSTALL		X	
030-00134-0001	RIGHT ANGLE CONN COAX	EA	1	TED Mfg. 5-30-102
047-10130-0002	BACKPLATE, ANTENNA	EA	1	
089-06908-0012	SCREW, AIRCRAFT	EA	4	
187-01807-0000	KA 91 GASKET	EA	1	

Earlier installation kits included a straight TNC coax connector, P/N 030-00134-0000.

The KA 92 Installation Kit (P/N 050-03318-0000), including its contents, is shown below.

P/N	DESCRIPTION	UM	-0000	VENDOR NAME & P/N
050-03318-0000	KA 92 INSTALL		X	
030-00134-0001	RIGHT ANGLE CONN COAX	EA	1	TED Mfg. 5-30-102
047-10735-0002	BACKPLATE, ANTENNA	EA	1	
089-05909-0012	SCREW, PHP 8-32x3/4	EA	4	
187-01831-0000	KA 92 GASKET	EA	1	

1.4.5 DATABASE

The KLN 94 is supplied with two different kinds of databases:

1) NAVIGATION DATABASE

This is required to be current for IFR non-precision approaches. Our navigation database is available on a twenty-eight day cycle.

2) CARTOGRAPHY DATABASE

This includes features such as roads, rivers, railroads, etc. and is provided for reference only. Cartography database updates are available on a less frequent basis than the navigation database updates. Updating the cartography database will require a cartridge exchange.

The KLN 94 navigation database cartridge and diskettes are available for three separate geographic areas. Database cartridges are available only for users in the United States Of America and Canada. Diskettes are available to all users. Also database files can be downloaded via the Internet at the following address: <http://www.gpsdatabase.com>

KLN 94 DATABASE	CARTRIDGE (navigation and cartography)	DISKETTE (navigation only)
Atlantic International Database	071-00163-0101	223-111YY-00CC
Pacific International Database	071-00163-0102	223-112YY-00CC
Americas Database	071-00163-0103	223-113YY-00CC

NOTE

YY represents the year of the database cycle.

CC represents the cycle of the database.

1.5 ACCESSORIES REQUIRED, BUT NOT SUPPLIED

1.5.1 Forced Air Cooling

A KA 33 Cooling Kit or equivalent is required for the KLN 94 installation.

DESCRIPTION	PART NUMBER
KA 33 Blower for 14 VDC installations	071-4037-00
KA 33 Blower for 28 VDC installations	071-4037-01
KA 33 Blower Installation Kit	050-02204-0000

1.5.2 Indicators and HSIs

DESCRIPTION
KI 202 or KI 206 (P/N 066-3034-XX) Navigation Indicator and Installation Kit (050-01524-0000)
KI 208A or KI 209A (P/N 066-3056-XX) Navigation Indicator and Installation Kit (050-01524-0000)
KPI 553A (P/N 066-3045-XX) Horizontal Situation Indicator and Installation Kit (050-01791-XXXX)
KPI 553B (P/N 066-3069-XX) Horizontal Situation Indicator and Installation Kit (050-02167-XXXX)
KI 525A (P/N 066-3046-XX) Horizontal Situation Indicator and Installation Kit (050-01334-XXXX)

NOTE

The KPI 553A/553B DME distance display is not compatible with the KLN 94.

The KPI 553A models that do not have an OBS knob on the indicator were special for the KNR 665 system and are not compatible with the GPSs.

1.5.3 CDI Indicator with "MSG" and "WPT" Annunciators

Some stand alone CDI indicators are available with WPT/MSG annunciators built in. One commonly used is the Model MD40-39, manufactured by Midcontinent Instrument, telephone (316) 683-5619. These devices have no resolver interface. The use of an OBS resolver will reduce pilot workload.

1.6 OPTIONAL ACCESSORIES

1.6.1 PC Interface Kit

The navigation database may be loaded directly from the PC to the KLN 94 installed in an aircraft by means of the bezel jack (refer to [Section 2.4.4.8](#) for details). To utilize the bezel jack for loading of the database, order kit part number 050-03612-0000.

If the installation was previously a KLN 89B installation and utilized an external jack, order interface kit P/N 050-03213-0000 in order to load the navigation database from a personal computer. The kit contains a ready to use cable which connects between the aircraft connector and the computer's 9 pin or 25 pin serial connector. The kit is necessary whether the user is loading from a Honeywell diskette or a database obtained via the Internet.

The cartography database is contained in the Sandisk cartridge. The cartography data is not updated as frequently as the navigation data.

It is necessary to swap cards to update the cartography data. Updating the navigation database will not compromise the cartography database.

Laptop computers used to load the database require the following:

1. IBM compatibility
2. An available Com 1,2,3, or Com 4 serial port

NOTE

The PC must be fully IBM compatible and must have a 3.5" high density diskette drive, If the database is loaded from a diskette sent from Honeywell. For more information, contact Honeywell Product Services by telephoning (913) 712-0600.

1.6.2 Annunciators and Switch/Annunciators

(Refer to I.B. 363 for additional information pertaining to switch/annunciators for GPS systems)

The devices shown below are Eaton 582/584 series switch/annunciators and are representative of those used in our original certification. They were chosen because of their excellent sunlight readable characteristics and meet or exceed the requirements of Advisory Circular 20-138. These are high quality devices and we encourage their use. However, there are other comparable devices on the market that may be substituted at the installer's/customer's choice.

These switch/annunciators are available through Honeywell Service Stock or direct from our supplier, LCOMP Inc. It is advantageous to order direct from LCOMP, if possible, in order to avoid additional price mark-ups. On international orders, it may be necessary to order through Honeywell as LCOMP, at the time of this publication, is not prepared to handle international orders. The address and telephone numbers for LCOMP are listed as follows:

LCOMP Aerospace Controls	(913) 438-4848 Telephone
c/o Carlton-Bates Co.	(800) 786-0617 Toll Free
9214 Bond St.	(913) 438-4839 Fax
Overland Park, KS 66214	

NOTE

The switch/annunciators listed below in many cases show two numbers. The part numbers that are shown in parentheses are devices previously called out and may be used until supply is depleted. The 031-00785-XXXX are the preferred Switch/Annunciator assemblies.

KLN 94 Enroute/Terminal Set for CDI or Elect. Mech. HSI Installations

The following switch/annunciators are being offered for CDI or HSI switching and annunciation in the KLN 94 IFR enroute/terminal installations. They are optional for KLN 94 VFR installations. The KLN 94 has internal annunciators. Hence, the external annunciators may be optional in some installations:

KLN 94/89/89B Annunciator Set - 28 VDC Lighting	
NAV / GPS Sw. Ann	031-00785-0711 or 031-00763-0711
WPT / MSG Ann.	031-00785-0505 or 031-00763-0505 / -0718

KLN 94/89/89B Annunciator Set - 14 VDC Lighting	
NAV / GPS Sw. Ann	031-00785-0712 or 031-00763-0712
WPT / MSG Ann.	031-00785-0762 or 031-00763-0762 / -0719

KLN 94 Approach Set for CDI or Elect. Mech. HSI Installations

The following switch/annunciators are being offered for CDI or HSI switching, APR switching, and annunciation in KLN 94 non-precision approach installations:

KLN 94/89B Annunciator Set - 28 VDC Lighting	
NAV / GPS Sw. Ann	031-00785-0711 or 031-00763-0711
WPT / MSG Ann.	031-00785-0505 or 031-00763-0505 / -0718
GPS APR ARM / ACT Sw. Ann.	031-00785-0766

KLN 94/89B Annunciator Set - 14 VDC Lighting	
NAV / GPS Sw. Ann	031-00785-0712 or 031-00763-0712
WPT / MSG Ann.	031-00785-0762 or 031-00763-0762 / -0719
GPS APR ARM / ACT Sw. Ann.	031-00785-0767

NAV/GPS Switch/Annunciator

Installations where the outputs from KLN 94 and an existing navigation system are switched between a common indicator or HSI may require some type of annunciation. A NAV/GPS switch/annunciator is available that provides both the annunciation and a switch contact to energize the switching relay(s) required for the switching of the outputs. This Switch/Annunciator is available in 5 V, 14 V, or 28 V versions as shown below.

LIGHTING	Honeywell P/N	Honeywell P/N
28 VDC	031-00763-0711	031-00785-0711
14 VDC	031-00763-0712	031-00763-0712
	(Eaton Series 584)	(Eaton Series 582)
	Old Style	Preferred

WPT/MSG Remote Annunciators
TWO FIELD ANNUNCIATORS (WPT/MSG)

LIGHTING	Honeywell P/N	Honeywell P/N
28 VDC	031-00763-0505	031-00785-0505
14 VDC	031-00763-0506	031-00763-0506
	(Eaton Series 584)	(Eaton Series 582)
	Old Style	Preferred

NOTE

(WPT) AND (MSG) will be in amber color. These annunciators will be deadface and readable only when lit.

GPS APR, ARM/ACTV Switch/Annunciator

A switch/annunciator can be used for arming or activating the approach mode. It will provide remote annunciation of ARM and ACTV and provide a momentary switch function to arm, disarm, or deactivate the Approach Mode and change the CDI scale factors. The KLN 94 may require an annunciator to display when approach is armed or active.

LIGHTING	Honeywell P/N
28 VDC	031-00763-776
14 VDC	031-00763-767
	(Eaton Series 582)

1.6.3 NAV/GPS Switching

Installations in which the outputs from a KLN 94 and an existing navigation system are being switched onto a common indicator will require some remote relay switching that is controlled by the NAV/GPS switch/annunciator.

1.6.4 Right Angle Connector

The part number for a right angle connector for the KA 91 or KA 92 antenna connection is 030-00134-0001. This right angle connector was originally an option but has been included in the installation kit as the standard connector.

1.7 LICENSE REQUIREMENTS

None.

1.8 RECOMMENDATIONS FOR IFR APPROVAL

1.8.1 Aircraft Logbook Entry

1.8.2 Aircraft Installation Requirements

NOTE

For the following subsections, refer to [Section 1.5](#) and [Section 1.6](#) for allowable configurations where applicable. Refer to [Section II](#) for illustrations.

1.8.2.1 TSO/JTSO'd Antenna

The antenna must be a TSO/JTSO'd KA 91, P/N 071-01545-0200 or KA 92 P/N 071-01553-0200. If the P/N of the KA 91 is not available, it may be identified by the serial number as the TSO/JTSO'd antennas have a five digit serial number.

1.8.2.2 Nav Instrumentation

The navigation information (D-Bar, Nav Flag, and To-From) must be displayed on an instrument in the pilot's panel. Electromechanical indicators are capable of displaying the variable scale factors of enroute, terminal, and approach modes.

1.8.2.3 OBS Interface

The use of an OBS resolver will reduce pilot workload during an instrument approach. It allows the OBS setting to be changed on the navigation indicator when the KLN 94 is operating in the OBS mode. Without the OBS resolver connection, the OBS may be changed from the KLN 94 controls. OBS mode is commonly used during procedure turns and holding patterns.

Some certification agencies may require the use of the OBS resolver for approach certification. Consult your approval agency for additional information. Refer to [Section 1.3](#) and [Section 2.3.6](#) for additional OBS information.

1.8.2.4 Switch/Annunciators

1.8.2.4.1 NAV/GPS (Switch/Annunciator)

If the navigation information is displayed on a shared primary indicator a switch/annunciator will be required to select and annunciate the source.

1.8.2.4.2 WPT/MSG (Annunciator)

The KLN 94 has internal annunciators. The “WPT” and “MSG” external annunciators may be required in some installations.

1.8.2.4.3 GPS APR, ARM/ACT (Switch/Annunciator)

A switch/annunciator can be used for arming, disarming, or deactivating the approach mode. It will provide remote annunciation of ARM and ACTV and provide a momentary switch function to arm and activate the Approach Mode and change the CDI scale factors. The KLN 94 may require an annunciator to display when approach is armed or active. Refer to [Section 1.6](#) for additional switch/annunciator information.

1.8.2.4.4 Altitude Source

An altitude source is required for IFR certification. The altitude may be derived from a compatible encoding altimeter and some RS 232 air data systems.

1.8.3 Approved Airplane Flight Manual Supplement

A flight manual supplement will need to be prepared and approved. The supplement may be prepared based on the sample, P/N 006-00839-0000. Refer to the [Flight Manual Supplement Procedures Appendix](#) for information on preparing a flight manual supplement and a copy of the STC approval.

1.8.4 Pilots Guide

The KLN 94 pilots guide must be placed in the aircraft in a location that is accessible to the pilot. The pilots guide is P/N 006-18207-0000.

1.9 INSTRUCTIONS FOR CONTINUED AIRWORTHINESS

The instructions for continued airworthiness given in the TC or STC approvals for this product supplements or supersedes the instructions for continued airworthiness in this manual.

Most Honeywell products are designed and manufactured to allow "on condition maintenance". On condition maintenance is described as follows; There are no periodic service requirements necessary to maintain continued airworthiness. No maintenance is required until the equipment does not properly perform it's intended function. When service is required, a complete performance test should be accomplished following any repair action. Consult the appropriate unit Maintenance/Overhaul Manual for complete performance test information.

SECTION II INSTALLATION

2.1 GENERAL INFORMATION

This section contains general suggestions and information to consider before installation of the KLN 94 GPS RNAV. Close adherence to these suggestions will assure optimum performance from the equipment.

NOTE

For aircraft equipped with a KLN 89B that is being replaced by a KLN 94 refer to [Appendix D](#), Direct Replacement of a KLN 89B with a KLN 94, at the end of this manual.

NOTE

The conditions and tests required for TSO/JTSA approval of this article are minimum performance standards. It is the responsibility of those desiring to install this article either on or within a specific type or class of aircraft to determine that the aircraft installation conditions are within TSO/JTSA standards. The article may be installed only if further evaluation by the applicant documents an acceptable installation and is approved by the Administrator.

2.2 UNPACKING AND INSPECTING EQUIPMENT

Exercise extreme care when unpacking the equipment. Make a visual inspection of the unit for evidence of damage incurred during shipment. If a claim for damage is to be made, save the shipping container to substantiate the claim. The claim should be promptly filed with the transportation company. It would be advisable to retain the container and packaging material after all equipment has been removed in the event that equipment storage or reshipment should become necessary.

2.3 EQUIPMENT INSTALLATION

2.3.1 AVIONICS COOLING REQUIREMENTS FOR PANEL MOUNTED EQUIPMENT

The greatest single contributor to increased reliability of all modern day avionics is to limit the maximum operating temperature of the individual units whether panel mounted or remote mounted. While modern day individual circuit designs consume much less electrical energy, watts per cubic inch dissipated within the avionics unit remains much the same due to the high density packaging techniques utilized. Consequently, the importance of providing cooling to the avionics stack is still with us today.

While each individual unit may or may not require forced air cooling, the combined heat load of several units operating in a typical avionics location will significantly degrade the reliability of the avionics if provisions for cooling are not incorporated in the initial installation. Failure to provide cooling to the equipment will lead to increased avionics maintenance costs and may also void the Honeywell warranty.

In the case of the KLN 94, installation of a KA 33, (P/N 071-4037-XX), or equivalent cooling system is required. Ram air cooling is not acceptable. For installation information on the KA 33 refer to the KA 33 installation manual, P/N 006-01069-XXXX or Installation Bulletin 258.

2.3.2 KLN 94 MECHANICAL INSTALLATION

The KLN 94 installation will conform to standards designated by the customer, installing agency, and existing conditions as to the unit location and type of installation. However, the following suggestions will assure a more satisfactory performance from the equipment.

A. Plan a location on the aircraft panel so that the KLN 94 is plainly visible to the pilot and so that he has complete access to all front panel controls. Check to be sure that there is adequate depth behind the panel for the mounting rack and all the connectors and cabling. Be sure that the mounting location is not close to heater vents or other sources of high heat.

B. Refer to [figure 2-3](#) for the panel cutout dimensions. Mark and cut the panel opening.

2.3.3 ANTENNA SELECTION

The KA 91 and KA 92 GPS active antennas, P/N 071-01545-0200 and 071-01553-0200 respectively, are the designated antennas for the KLN 94.

2.3.4 ANTENNA INSTALLATION CONSIDERATIONS

The antenna should be mounted on top of the fuselage near the cockpit. Avoid mounting the antenna near any projections, the propeller, and the T-tail of the aircraft, where shadows could occur. It is recommended that there be a separation of at least 3 ft between the KLN 94 GPS antenna and any VHF Comm antenna on the aircraft. Antenna baseplate must be level within $\pm 5^\circ$ in both axes when the aircraft is in level flight. If the antenna is tilted more than 5° or is mounted close to other objects that shadow it, loss of some of the satellites will occur and system performance may be degraded. Antenna cable and connector information, including vendor information, is listed below. Refer to [figure 2-10](#) (TNC) and [figure 2-11](#) (BMA) for cable/connector assembly instructions for the 0 to 40 feet category using RG 400/U or RG 142B/U. Refer to [Figure 2-12](#) (for both TNC and BMA) for the 0 to 80 feet and 0 to 100 feet categories.

NOTE

KA 91/92 nominal gain and noise figures are 26.5 dB and 2.3 dB respectively. With 0.050 ice on radome, gain will not decrease by more than 2.0 dB when viewing a satellite from 30° above the horizon to zenith, as compared to a no ice condition.

CABLE LENGTH	CABLE PART NUMBER	BMA CONNECTOR	TNC CONNECTOR	MAXIMUM ALLOWABLE LOSS (dB)
0 to 40 ft	P/N: 024-00002-0000 VPN: RG142B/U	P/N: 030-00101-0002 VPN: TED Mfg. 9-30-10	P/N: 030-00134-0001 VPN: TED Mfg. 5-30-102	8.0
	P/N: 024-00051-0060 VPN: RG400/U	P/N: 030-00101-0002 VPN: TED Mfg. 9-30-10	P/N: 030-00134-0001 VPN: TED Mfg. 5-30-102	8.0
0 to 80 ft	P/N: 024-00072-0000 VPN: ECS 311601	P/N: 030-00452-0000 VPN: TED Mfg. 9-30-26	P/N: 030-00108-0002 VPN: TED Mfg. 5-10-307	8.0
0 to 100 ft	P/N: 024-00071-0000 VPN: ECS 311201	P/N: 030-00452-0001 VPN: TED Mfg. 9-30-25	P/N: 030-00108-0003 VPN: TED Mfg. 5-10-306	8.0
100 to 165 ft	Contact TED, ECS or PIC for complete cable/connector assembly.			

NOTE

A right angle antenna connector is available from Honeywell (P/N 030-00134-0001) or from TED.

TED Manufacturing Corp.
11415 Johnson Drive
Shawnee, Kansas 66203
Tel: (913) 631-6211

Electronic Cable Specialists
5300 West Franklin Drive
Franklin, Wisconsin 53132
Tel: (800) ECS-WIRE
or (414) 421-5300

PIC Wire and Cable
N53 W 24747 S. Corporate Circle
P.O. Box 330
Sussex, Wisconsin 53089
Tel: (800) 742-3191
or (262) 246-0500

2.3.5 ANTENNA MECHANICAL INSTALLATION

2.3.5.1 General

To maintain good performance from the antenna system, do not wax or paint the antenna.

2.3.5.2 Installation Procedure

- A. Using the correct template for the antenna chosen, mark the mounting holes on the aircraft fuselage.
- B. Drill and/or punch the required holes.

- C. Use a piece of fine sandpaper or emery cloth to sand the area on the fuselage skin on which the doubler plate for the antenna is to be mounted and on the aircraft skin under where the antenna will be mounted.
- D. Apply Alumiprep No. 33, P/N 016-01127-0000, to both the inside and outside areas of the fuselage and to the back of the doubler plate. Follow the directions on the container to cleanse the metal of any left over residue.
- E. Apply Alodine, P/N 016-01128-0000, to both locations following the directions on the container. This is used to ensure good bonding of the antenna and to prevent oxidation.
- F. Refer to [Figure 2-5](#) for the KA 91 installation drawing or [Figure 2-8](#) for the KA 92 installation drawing and mount the antenna as shown. First rivet the doubler plate in place. It is imperative that the doubler plate make a good electrical bond with the inside of the aircraft skin and that the antenna itself be well bonded to the aircraft.
- G. When installing the KLN 94 antenna (KA 91/KA 92) do not exceed 50 inch/lbs of torque on the antenna mounting screws.
- H. Apply a bead of sealant around the base of the antenna and seal the antenna mounting screw holes to prevent water damage.

2.3.6 ELECTRICAL INSTALLATION

2.3.6.1 General Information

The KLN 94 will operate with an input voltage from 11 to 33 VDC but the front panel lighting circuit must be wired for either +14 VDC or +28 VDC, depending upon the aircraft lighting bus. Refer to the KLN 94 interconnect diagram for wiring details.

- A. The installing facility will supply and fabricate all external cables. The required connectors are supplied as part of the installation kit.
- B. The length and routing of the external cables must be carefully planned before attempting the actual installation. Avoid sharp bends or locating the cable near aircraft control cables.
- C. The KLN 94 and associated wiring must be kept at least a minimum of 3 ft. from high noise sources and not routed with cables from high power sources to insure optimum performance from the system.
- D. Do not route the antenna cable near any cable used for a transmitting antenna. Prior to installing the KLN 94 itself, a point to point continuity check of the wiring harness should be done to verify proper wiring. The aircraft power input to the unit should be made to insure that power is applied to only the specified power pin(s).

2.3.6.2 Functional Pinout Descriptions

This section gives a brief description of some of the inputs and outputs of the KLN 89/89B. It is provided so the installer can determine what specific wiring needs to be done to the aircraft in which the unit is to be installed. Unless otherwise specified, pins not used are to be left open.

CONNECTOR P941

Pin 1; GENERAL RS 232 IN

Pin 1 is the RS 232 input. The KLN 94 must be configured correctly for the type of equipment (or no equipment) connected to this input. Refer to [Section 2.4.1](#) for the configuration procedure.

It is not necessary to connect this input to the GENERAL RS 232 OUT when this input is not used as the “No Fuel Mgt Sys” and “No Air Data” configuration choices indicate this input is unused and inhibit the “No RS-232 Data” message. For specific label information, refer to [RS 232 Format Definitions Appendix](#).

Pin 2; GENERAL RS 232 OUT

The KLN 94 outputs data in RS 232 format on this pin. It can be used to interface with certain types of ELT's, fuel sensors, moving map displays, and fuel management systems. For specific label information, refer to [RS 232 Format Definitions Appendix](#).

Pin 3; DATA LOADER RS 232 IN

Pin 3 inputs Data Loader information in RS 232 format. It can be used to interface with a laptop IBM compatible PC to load the database.

Pin 4; DATA LOADER/QUICKTUNE™ RS 232 OUT

Pin 4 outputs Data Loader information in RS 232 format. It can be used to interface with a laptop IBM compatible PC to load the database and to quick-tune some VHF COMM units..

Pin 5; SPARE RS 232 IN

Pin 5 is a spare RS 232 input.

Pin 6; GPS SENSOR RS 232 OUT

Pin 6 is a GPS Sensor RS 232 output; Typically used for RPGWS interface.

Pin 7; OBI SYNC

Pin 8; OBI CLOCK

Pin 9; OBI DATA

This is a three wire data bus that provides bearing to the active waypoint. The data is in Honeywell format and can be used to drive certain Honeywell RMI units.

The output can also be converted by a Honeywell KDA 692 which provides standard 4-wire SINE/COSINE OBI information.

Pin 10; LATERAL DEV FLAG+

Pin 11; LATERAL DEV FLAG-

Pin 12; VERTICAL DEV FLAG+

Pin 13; VERTICAL DEV FLAG-

These are deviation flag outputs. DEV FLAG+ outputs with respect to DEV FLAG-. For the specifications on these outputs refer to [Section 1.3](#) of this manual.

Pin 14; A/C GROUND

Pin 14 is tied to aircraft ground. Wiring harness shields are not to be terminated on this pin. Refer to [Figure 2-17](#).

Pin 15; WAYPOINT ANNUNCIATE

Pin 15 is the Waypoint Alert annunciator output. This output is tied to a remote annunciator lamp. When the line is pulled low the annunciator lamp will illuminate. The annunciator will be on whenever waypoint alerting is occurring. For more complete information refer to the KLN 94 Pilots Guide, P/N 006-18207-0000.

Pin 16; MESSAGE ANNUNCIATE

Pin 16 is the Message annunciator output. This output is tied to a remote annunciator lamp. When the line is pulled low the annunciator lamp will illuminate. The annunciator will be on whenever the message prompt on the KLN 94 is on. For more complete information refer to the KLN 94 Pilots Guide, P/N 006-18207-0000.

Pin 17; APPROACH ARM ANNUNCIATE

Pin 17 is the Approach Arm annunciator output. This output is tied to a remote annunciator lamp. When the line is pulled low the annunciator lamp will illuminate. The annunciator will be on whenever the unit is in the approach arm mode. For more complete information refer to the KLN 94 Pilots Guide, P/N 006-18207-0000.

Pin 18; APPROACH ACTIVE ANNUNCIATE

Pin 18 is the Approach Active annunciator output. This output is tied to a remote annunciator lamp. When the line is pulled low the annunciator lamp will illuminate. The annunciator will be on whenever the unit is in the approach active mode. For more complete information refer to the KLN 94 Pilots Guide, P/N 006-18207-0000.

Pin 19; ALTITUDE ALERT ANNUNCIATE

Pin 19 is the Altitude Alert output pin. The altitude alert feature can be enabled or disabled at installation time from the maintenance configuration pages as described in [Section 2.4.1](#)

This feature is normally disabled if another altitude alerter (selector) is already installed in the aircraft. If altitude alerting is enabled, the pilot can choose to turn it on or off. If it is disabled, the pilot is not able to turn it on.

Pin 20; SPARE ANNUNCIATOR 1

Pin 21; SPARE ANNUNCIATOR 2

Pins (20-21) are spare annunciator outputs.

Pin 22; ROLL STEERING VALID --This is a Roll Steering Superflag. (same logic as other superflags.)

Pin 23; ROLL STEERING HI-- Combined with Roll Steering LO, this provides a DC Roll Steering Command to the Autopilot

Pin 24; LIGHTING 28V/LO

Pin 25; LIGHTING 14V

The lighting bus will use the DC power input pin as lighting low. For 14 V operation, LIGHTING 28V/LO is connected to ground and LIGHTING 14V is connected to the 14 V panel lighting bus. For 28 V operation, LIGHTING 28V/LO is connected to the 28 V panel lighting bus and LIGHTING 14V is not connected.

CONNECTOR P942

Pin 1; TEST

Pin 1, when grounded on power-up, will place the unit in the test mode. Once in the test mode, the unit will remain in that mode until power to the unit is turned off. Test mode is provided to assist in manufacturing and field service troubleshooting.

Pin 2; TAKE HOME

Pin 2, when grounded, places the KLN 94 in Take-Home mode which is used for trip planning and flight simulation. It performs as if it is receiving adequate GPS signals to determine its position. It displays the latitude and longitude of its last known position or of whatever position it is initialized to on the Setup Page. Pin 2 should always be left open in the aircraft installation. Take-Home mode must not be allowed during actual flight.

Pin 3; SPARE IN 1

Pin 4; SPARE IN 2

Pin 5; SPARE IN 3

Pin 6; ROLL STEERING LO-- Combined with Roll Steering HI provides a DC Roll Steering Signal.

Pin 7; SPARE IN 0

Pin 8; APPROACH ARM IN

Pin 8 is used as a select input. If the installation is not certified for approach, the external switch/annunciator is not needed.

If the installation is approved for approach and the external switch/annunciator is installed, then a momentary ground on pin 8 will alternately arm or disarm the approach mode.

Pin 9; LATERAL SUPER FLAG

Pin 10; VERTICAL SUPER FLAG

On superflag outputs, a logic high shall be ≥ 18 VDC when the voltage at pin 19 is ≥ 24.8 VDC. A logic high shall be ≥ 10 VDC when the voltage at pin 19 is ≥ 12.4 VDC. A logic high shall be ≥ 20 VDC when the voltage at pin 19 is $+ 27.5$ VDC. A logic low shall be ≤ 3.5 VDC.

Pin 11; LATERAL DEV +L

Pin 12; LATERAL DEV +R

Pin 13; VERTICAL DEV +UP

Pin 14; VERTICAL DEV +DOWN

These pins are deviation outputs and function as differential pairs. For the specifications on these outputs, refer to [Section 1.3](#) of this manual.

Pin 15; ALTITUDE ALERT AUDIO

Pin 16; ALTITUDE ALERT AUDIO LO

These pins represent the Altitude Alert Audio output, which is active whenever ALTITUDE ALERT ANNUNCIATE is active.

Pin 17; FCS LOC ENG

This annunciator is active when the lateral deviation scale factor is 0.3 nm. It is also active while the scale is transitioning from 1.0 nm down to 0.3 nm.

Pin 18; A/C POWER MONITOR

Pin 18 is the aircraft power monitor. It senses voltages ranging from 0 to 33 V. The KLN 94 can be configured to allow the selection of a voltage alert set point and a voltage alert delay interval for use with this input. Refer to [Section 2.4.1](#) for the configuration procedure. The “Low Bus Voltage, Check Charging System” message is displayed when voltage at this pin is below the voltage alert set point for greater than the voltage alert delay interval.

Pin 19; 11-33 VDC A/C POWER

Pin 19 is the DC aircraft power input. The KLN 94 will accept from 11 VDC to 33 VDC input power.

Pin 20; A/C GROUND

Pin 20 is tied to aircraft ground. Wiring harness shields are not to be terminated on this pin. Refer to [Figure 2-17](#).

Pin 21; D4

Pin 22; A1

Pin 23; A2

Pin 24; A4

Pin 25; B1
Pin 26; B2
Pin 27; B4
Pin 28; C1
Pin 29; C2
Pin 30; C4

These pins are gray code altitude inputs from an encoding altimeter. If the KLN 94 is paralleled with another unit such as a transponder, it may be necessary to install isolation diodes between one or both units and the encoder. The KLN 94 has diodes already installed internally.

Pin 31; GPS DISPLAYED

This pin is used as an input to tell the unit whether an external indicator is connected to the analog OBS resolver inputs, in which case it will be high. This pin will be grounded if an indicator is not connected or coupled to the unit.

Pin 32; +TO
Pin 33; +FROM

These outputs function like the outputs from standard navigation converters. For the specifications on these outputs, refer to [Section 1.3](#) of this manual.

Pin 34; OBS OUT
Pin 35; OBS SIN
Pin 36; OBS COS
Pin 37; OBS RETURN

These pins are the OBS Resolver Interface. This interface is compatible with indicators that are electrically zeroed (EZ) at 300 degrees and indicators that are omni-ranged zero at 300 degrees. This interface will operate properly with either “0.85 gain” resolvers or “0.41 gain” resolvers with no special programming requirements. OBS Resolver Out is a 450 Hz output used to excite the resolver. The resolver output voltage is then received by the OBS Resolver sine and cosine inputs.

CONFIGURATION MODULE

The configuration module is a separate module from the main rear I/O connector. It is a serial EEPROM containing at least 32 bytes or 16, 16 (sixteen) 16-bit words of capacity.

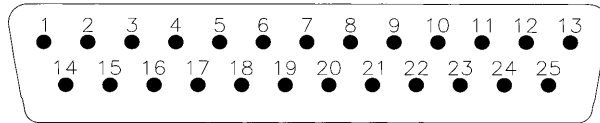

P941

1	←	-----	GENERAL RS 232 IN
2		-----	→ GENERAL RS 232 OUT
3	←	-----	DATA LOADER RS232 IN
4		-----	→ DATA LOADER/QUICKTUNE™ RS 232 OUT
5	←	-----	SPARE RS 232 IN
6		-----	→ GPS SENSOR RS 232 OUT
7		-----	→ OBI SYNC
8		-----	→ OBI CLOCK
9		-----	→ OBI DATA
10		-----	→ LATERAL DEV FLAG +
11		-----	→ LATERAL DEV FLAG -
12		-----	→ VERTICAL DEV FLAG +
13		-----	→ VERTICAL DEV FLAG -
14	←	-----	A/C GROUND
15		-----	→ <u>WAYPOINT ANNUNCIATE</u>
16		-----	→ <u>MESSAGE ANNUNCIATE</u>
17		-----	→ <u>APPROACH ARM ANNUNCIATE</u>
18		-----	→ <u>APPROACH ACTIVE ANNUNCIATE</u>
19		-----	→ <u>ALTITUDE ALERT ANNUNCIATE</u>
20		-----	→ <u>SPARE ANNUNCIATE 1</u>
21		-----	→ <u>SPARE ANNUNCIATE 2</u>
22		-----	→ ROLL STEERING VALID
23		-----	→ ROLL STEERING HI
24	←	-----	→ LIGHTING 28V/LO
25	←	-----	→ LIGHTING 14V
	←	INPUTS	→ OUTPUTS

Figure 2-1 KLN 94 P941 CONNECTOR PIN FUNCTIONS

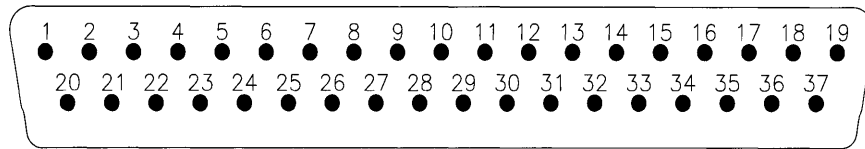

P942

1	←	-----	<u>TEST</u>
2	←	-----	<u>TAKE HOME</u>
3	←	-----	<u>SPARE IN 1</u>
4	←	-----	<u>SPARE IN 2</u>
5	←	-----	<u>SPARE IN 3</u>
6		-----	→ ROLL STEERING LO
7	←	-----	<u>SPARE IN 0</u>
8	←	-----	<u>APPROACH ARM IN</u>
9		-----	→ LATERAL SUPER FLAG
10		-----	→ VERTICAL SUPER FLAG
11		-----	→ LATERAL DEV +L
12		-----	→ LATERAL DEV +R
13		-----	→ VERTICAL DEV +UP
14		-----	→ VERTICAL DEV +DOWN
15		-----	→ ALTITUDE ALERT AUDIO
16		-----	→ ALTITUDE ALERT AUDIO LO
17		-----	→ FCS LOC ENG
18	←	-----	A/C POWER MONITOR
19	←	-----	11-33 VDC AC POWER
20	←	-----	A/C GROUND
21	←	-----	D4
22	←	-----	A1
23	←	-----	A2
24	←	-----	A4
	←	INPUTS	OUTPUTS →

Figure 2-2 KLN 94 P942 CONNECTOR PIN FUNCTIONS
(Sheet 1 of 2)

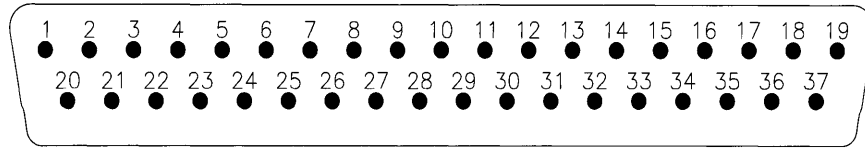

P942

25	←	-----	B1
26	←	-----	B2
27	←	-----	B4
28	←	-----	C1
29	←	-----	C2
30	←	-----	C4
31	←	-----	GPS DISPLAYED
32		-----	→ +TO
33		-----	→ +FROM
34		-----	→ OBS OUT
35	←	-----	OBS SIN
36	←	-----	OBS COS
37		-----	→ OBS RETURN
	←	INPUTS	OUTPUTS →

Figure 2-2 KLN 94 P942 CONNECTOR PIN FUNCTIONS
(Sheet 2 of 2)

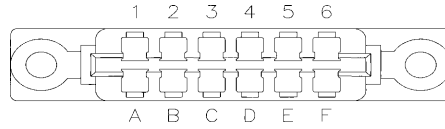

P943

1	-----	→	EXT_EEPRM_CS
2	←-----		EXT_EEPRM
3	←-----		TMCP_ENABLEn
4	-----	→	+5 V
5	←-----		RTI_TAKEHOME_ENABLEn
6	←-----		TMCP_IN
A	-----	→	SERIAL OUT
B	←-----		SERIAL_IN
C	←-----		SERIAL_CLK
D	-----		GROUND
E	-----		GROUND
F	-----	→	TMCP_OUT
	←	INPUTS	OUTPUTS →

Figure 2-3 KLN 94 P943 CONNECTOR PIN FUNCTIONS

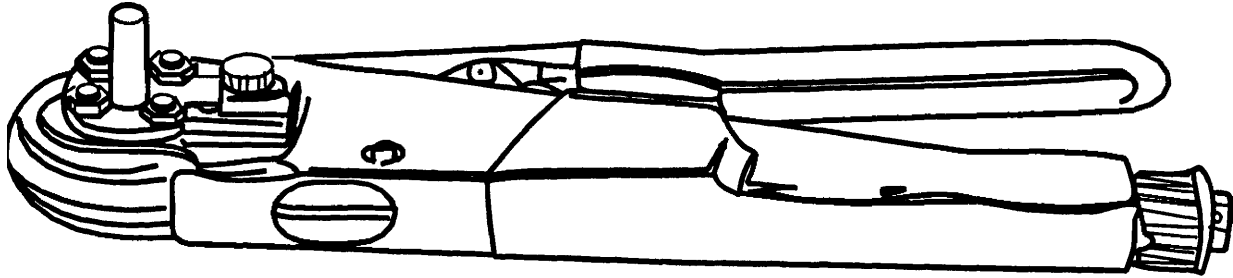

**CRIMPING TOOL P/N: 005-02012-0021
BUCHANAN P/N: 612118
POSITRONICS P/N: 9507-0-0-0**

**POSITIONER P/N: 005-02012-0023
BUCHANAN P/N: 612513
POSITRONICS P/N: 9502-5-0-0 (20-30 AWG)
POSITRONICS P/N: 9502-11-0-0 (18 AWG)**

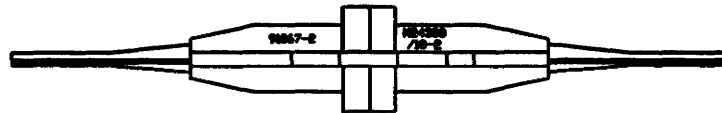

**INSERTION/EXTRACTION TOOL P/N: 005-02012-0025
AMP P/N: 91067-2
MIL SPEC P/N: M24308/18-12
POSITRONICS P/N: M81969/1-02**

FIGURE 2-4 CRIMPING AND INSERTION/EXTRACTION TOOLS

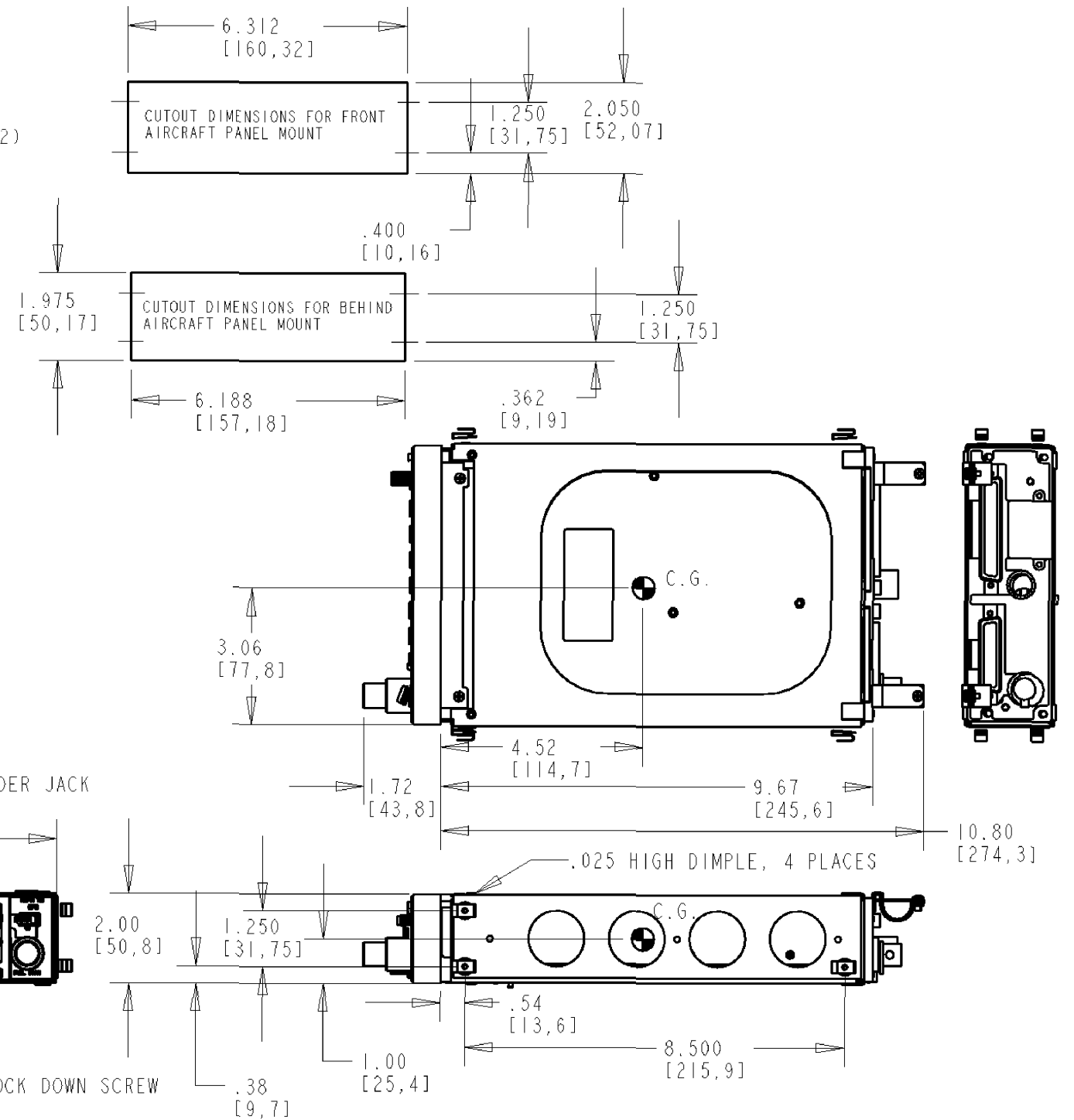
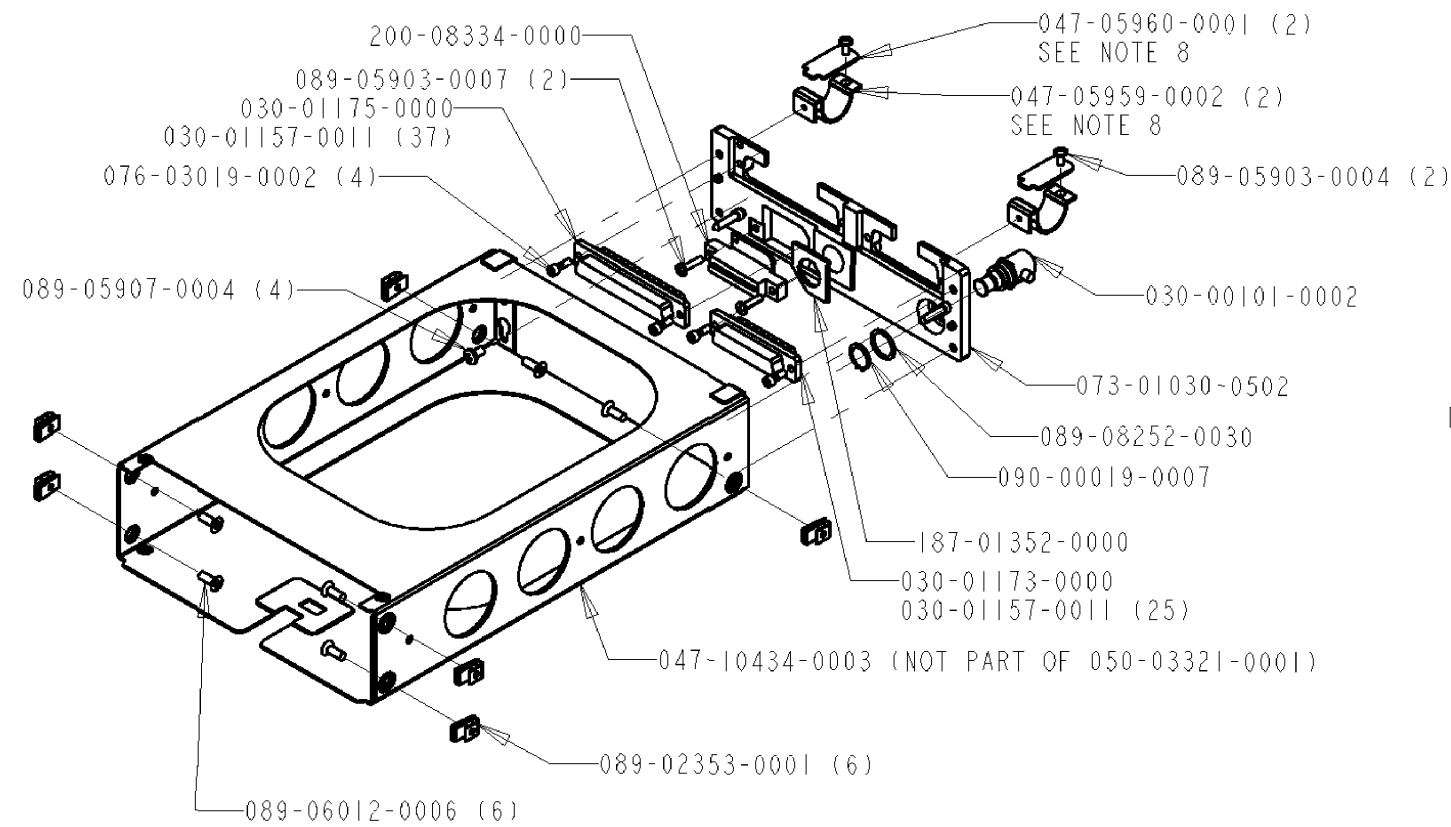

- NOTES:
- USE THIS PAGE (SHEET 2/2) FOR KLN 94.
 - ALL DIMENSIONS ARE IN INCHES [MILLIMETERS].
 - UNIT WEIGHT: 3.00 LBS [1.35 KG],
WEIGHT WITH MOUNTING RACK: 3.60 LBS [1.62 KG].
 - TOLERANCE FOR PANEL CUTOUTS: +0.030 [+0.76] / -0.000 [0.00].
 - REFER INSTALLATION MANUAL FOR COOLING REQUIREMENTS.
 - TO DETERMINE STACK HEIGHT, USE THE HEIGHT DIMENSIONS OF FRONT BEZEL.
 - WHEN INSTALLING TWO OR MORE PANEL MOUNTED UNITS IN A STACK, THE MOUNTING TRAY SHALL BE .050 [1.27] APART. MOUNTING TRAY HAVE 0.025 [0.63] DIMPLES BUILT IN TOP AND BOTTOM, SO THAT TWO TRAYS WILL AUTOMATICALLY BE SPACED PROPERLY.
 - PRIOR TO FASTEN OF 047-05959-0002 AND 047-05960-0001 WRAP WIRE BUNDLE WITH ELECTRICAL FRICTION TAPE TO AVOID WIRE CHAFING.
 - 030-00230-0000 & 057-05621-0000 ARE NOT USED ON KLN 94.
 - 057-05628-0000 IS NOT SHOWN.

FIGURE 2-5 KLN 94 INSTALLATION DRAWING
Dwg. No. 155-06020-0000 Rev. AC

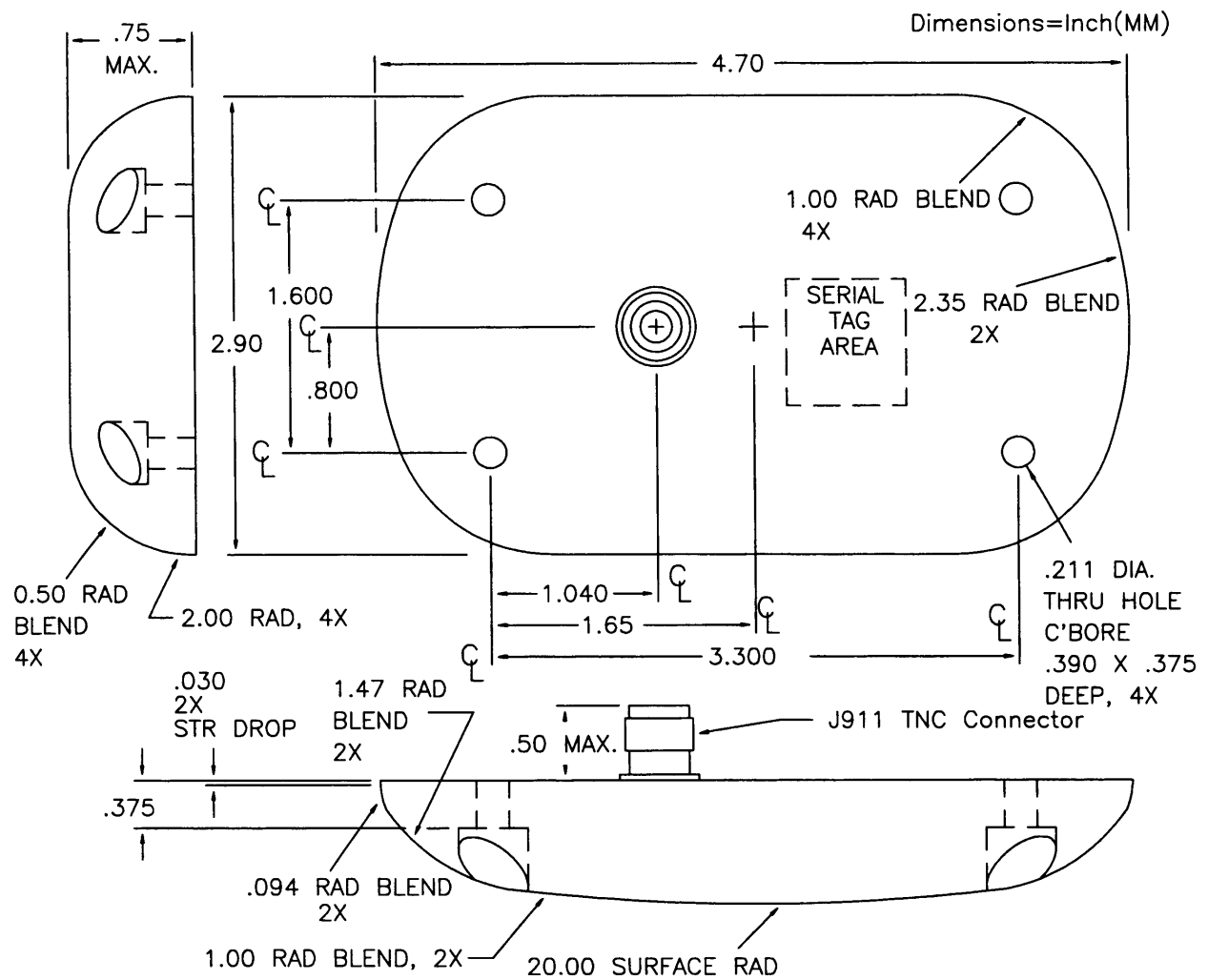
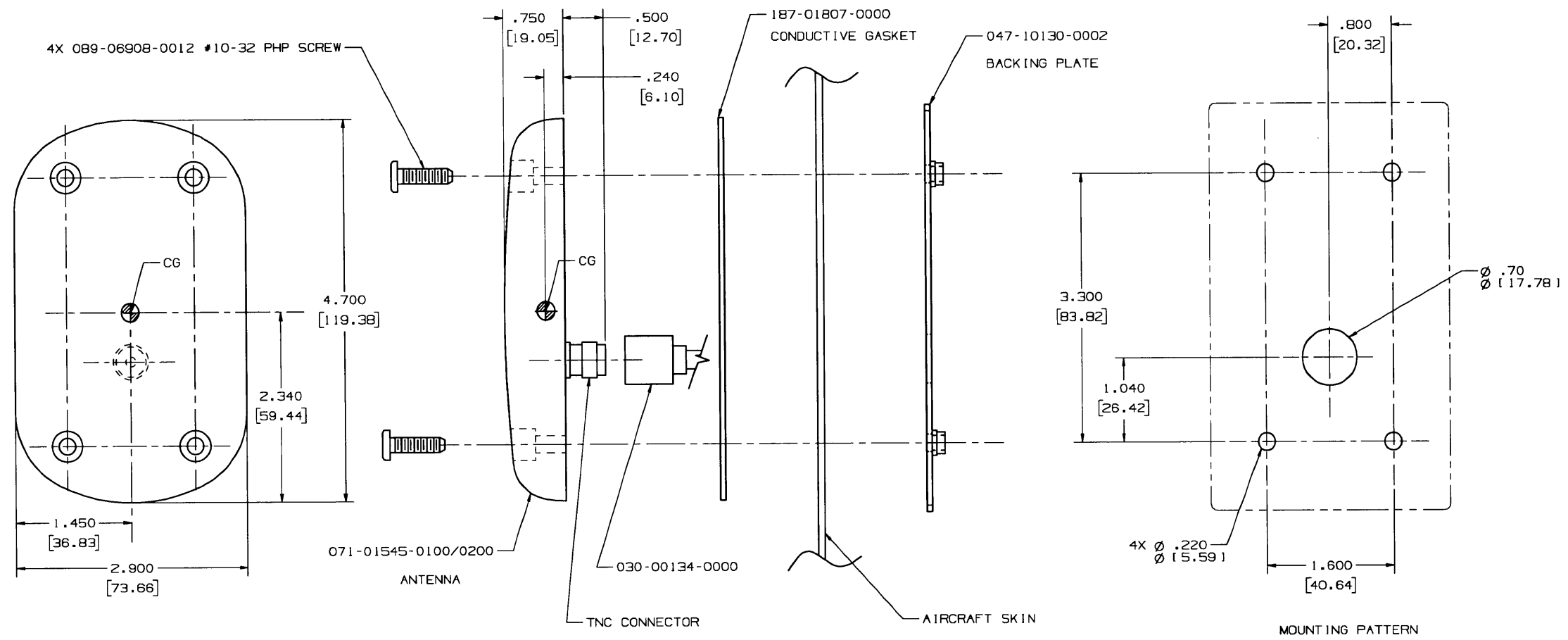

FIGURE 2-6 KA 91 OUTLINE
 Dwg. No. 071-01545-0200 Rev. 4

THIS PAGE IS RESERVED.



NOTES:

1. REMOVE PAINT IN AREA OF ANTENNA INSTALLATION.
2. DIMENSIONS IN INCHES [MILLIMETERS]
3. FOR BEST PERFORMANCE, BOND BETWEEN AIRCRAFT AND ANTENNA TO BE 10 MILLIOHMS RESISTANCE OR LESS.
4. UNIT WEIGHT .5 LBS [.227 KG.]
5. FILL MOUNTING SCREW HOLES WITH RTV SEALANT. APPLY WHITE RTV SEALANT AROUND BASE OF INSTALLED ANTENNA. KPN 016-01129-0000 OR EQUIVALENT.
6. ANTENNA SHOULD BE MOUNTED ±5° WITH AIRCRAFT AT LEVEL FLIGHT ATTITUDE.
7. DO NOT PAINT ANTENNA
8. AIRSPEED RATING 600 KTS MAX TAS.

REF. B/M 050-03195-0000

FIGURE 2-7 KA 91 INSTALLATION DRAWING
Dwg. No. 155-05999-0000 Rev. 5

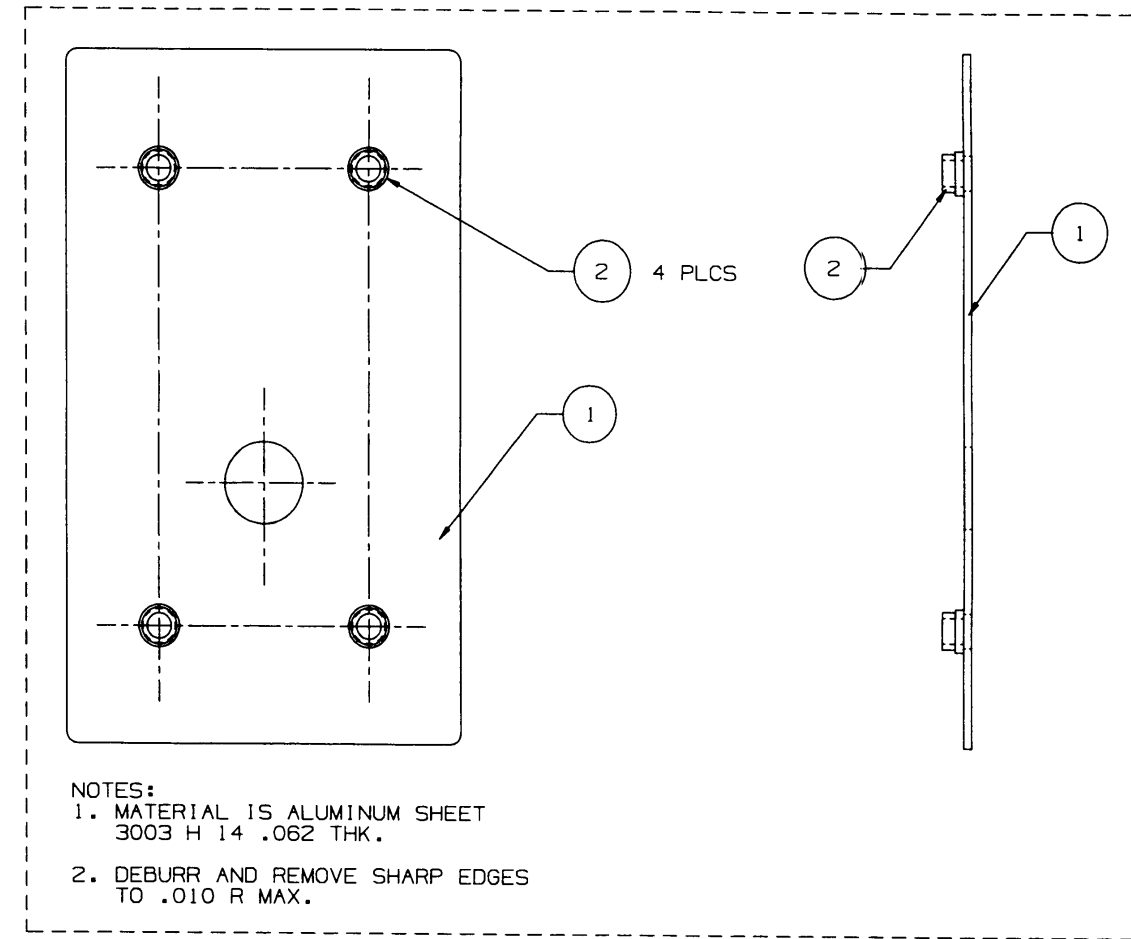
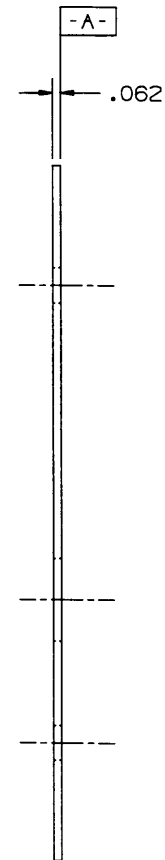
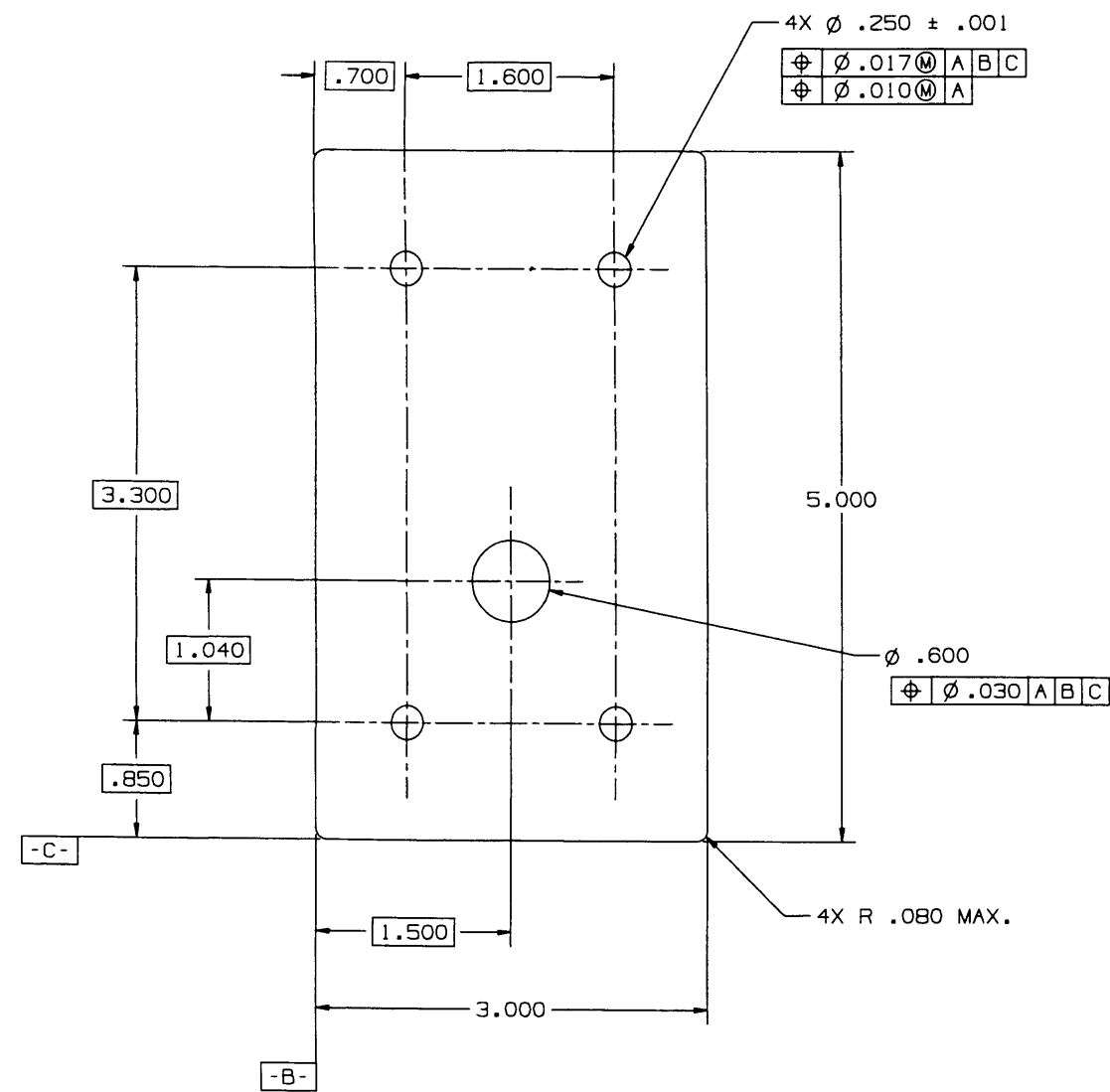

ALTERNATE VIEW

FIGURE 2-8 KA 91 BACKPLATE OUTLINE
Dwg. No. 155-10130-0000/0002 Rev. 2

EFFECTIVE FOR S/N's: < 40,000

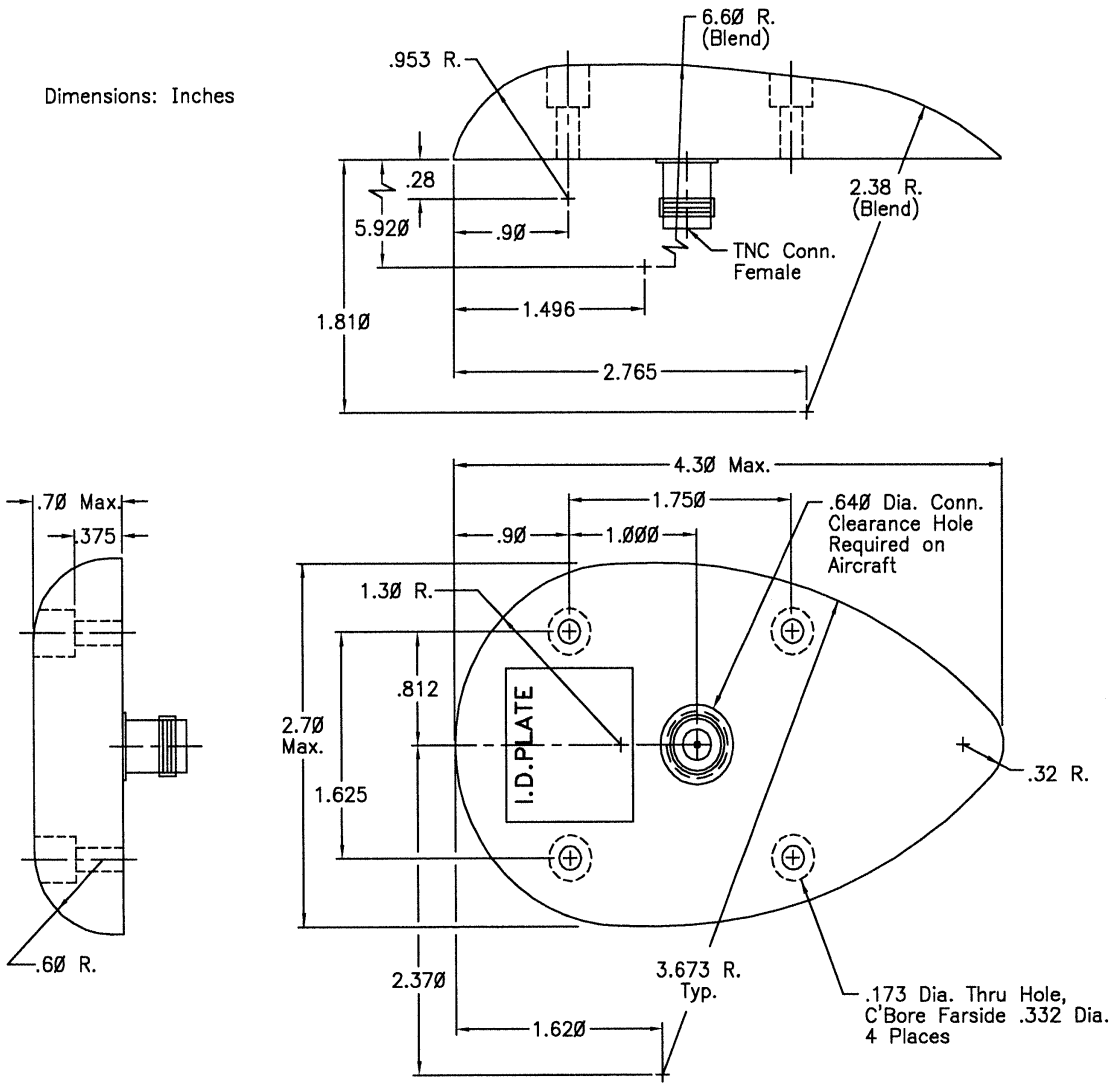

Note: Ø71-Ø1553-Ø2000 is a TSO'd Antenna.

FIGURE 2-9 KA 92 OUTLINE
 Dwg. No. 071-01553-0200 Rev. AB
 Sheet 1 of 3

EFFECTIVE FOR S/N's: $\geq 40,000$

Dimensions: Inches

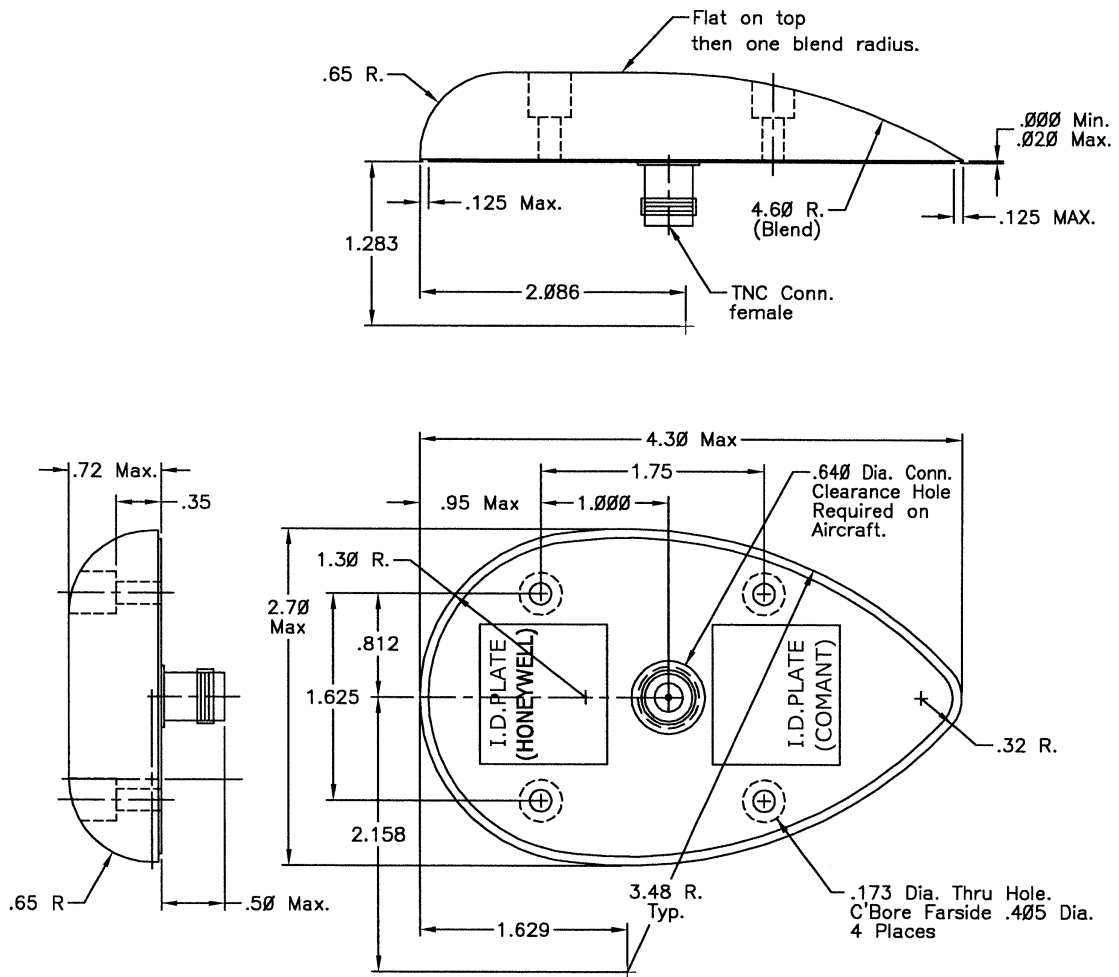

Note: Ø71-Ø1553-Ø2000 is a TSO'd Antenna.

FIGURE 2-9 KA 92 OUTLINE
 Dwg. No. 071-01553-0200 Rev. AB
 Sheet 2 of 3

NOTES

1. For best performance, electrical bond between aircraft and antenna should be less than 10 milliohms measured from TNC connector to aircraft skin.
2. Antenna to be mounted with four 8-32 x 3/4 inch long Pan Head phillips stainless steel screws (Honeywell P/N 089-05909-0012).
3. Serial tags to be vendor supplied in accordance with Honeywell P/N 057-05753-0000 and Comant P/N B40585-1.
4. Airspeed Rating: 600 knots TAS maximum.
5. Antenna to be installed with installation kit Honeywell part number 050-03318-0000.
6. Antennas to be bulk packaged as per good commercial practice.
7. Finished antenna assembly to be tested utilizing Honeywell Test Chamber 190-2361-XX or equivalent, and CHU Associates source antenna model CA3224, or Tecom Model 401163-2.

FIGURE 2-9 KA 92 OUTLINE
Dwg. No. 071-01553-0200 Rev. AB
Sheet 3 of 3

THIS PAGE IS RESERVED

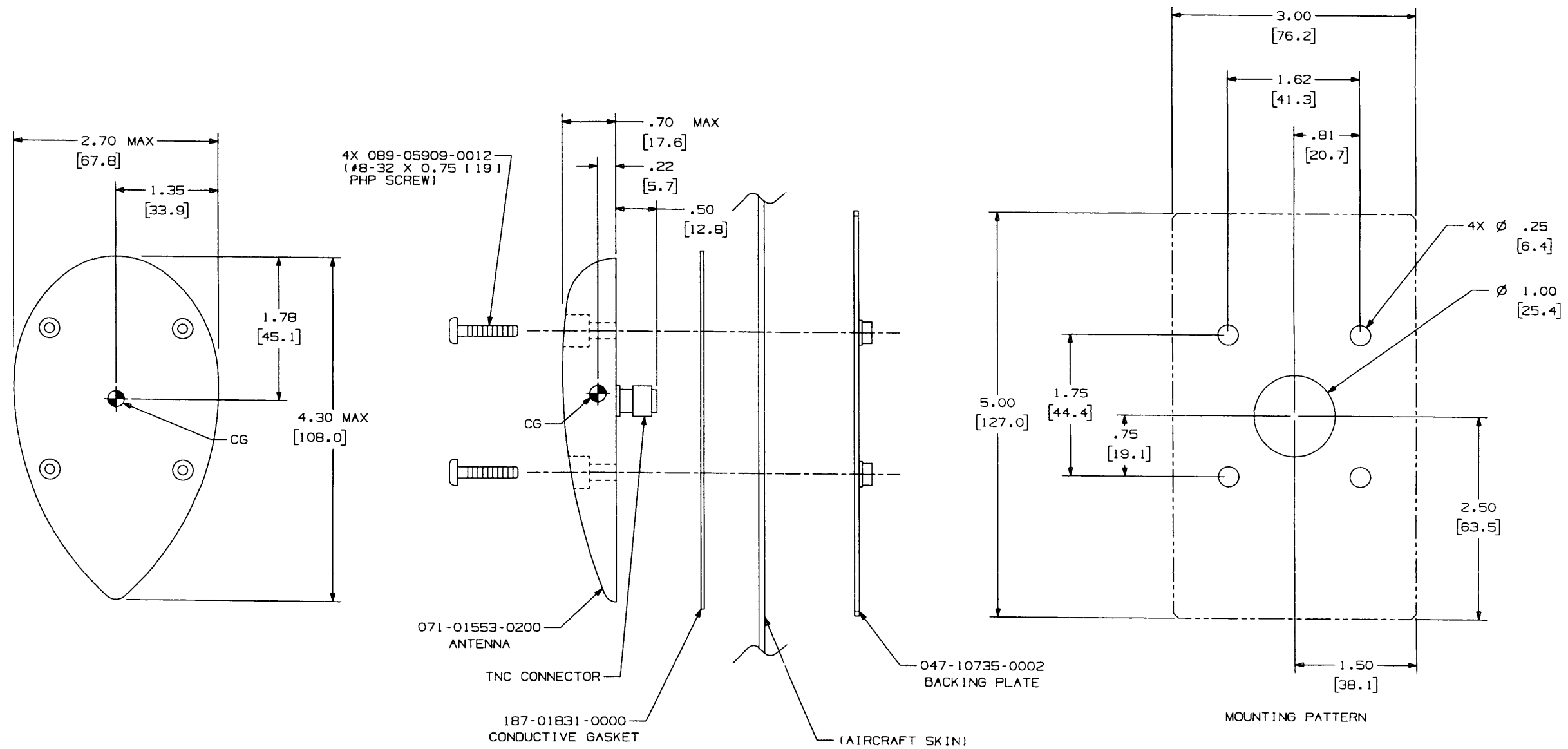

NOTES UNLESS OTHERWISE SPECIFIED:

1. REMOVE PAINT IN AREA OF ANTENNA INSTALLATION.
2. DIMENSION IN INCHES (MILLIMETERS)
3. FOR BEST PERFORMANCE, BOND BETWEEN AIRCRAFT AND ANTENNA TO BE 10 MILLIOHMS RESISTANCE OR LESS.
4. UNIT WEIGHT IS .27 LBS (.12 KG)
5. APPLY WHITE RTV SEALANT AROUND BASE OF INSTALLED ANTENNA. FILL MOUNTING SCREW HOLES WITH RTV SEALANT. (KPN 016-01129-0000 OR EQUIVALENT)
6. ANTENNA SHOULD BE MOUNTED LEVEL ±5° WITH AIRCRAFT AT LEVEL FLIGHT ATTITUDE.
7. DO NOT PAINT ANTENNA.
8. AIRSPEED RATING 600KTS MAX TAS.

FIGURE 2-10 KA 92 INSTALLATION DRAWING
Dwg. No. 155-06019-0000 Rev. 2

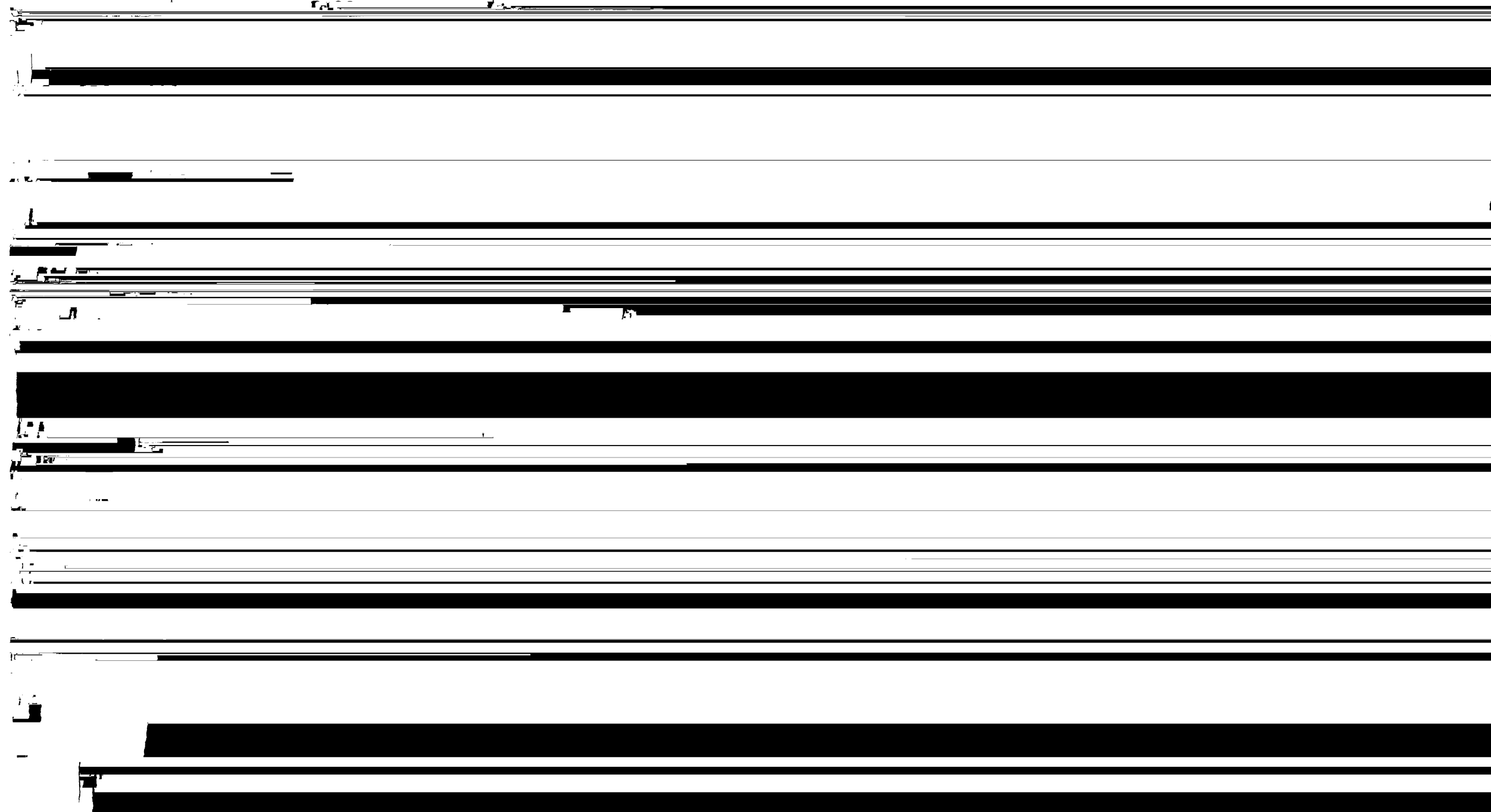

FIGURE 2-11 KA 92 BACKPLATE OUTLINE
Dwg. No. 047-10735-0000 Rev. 1

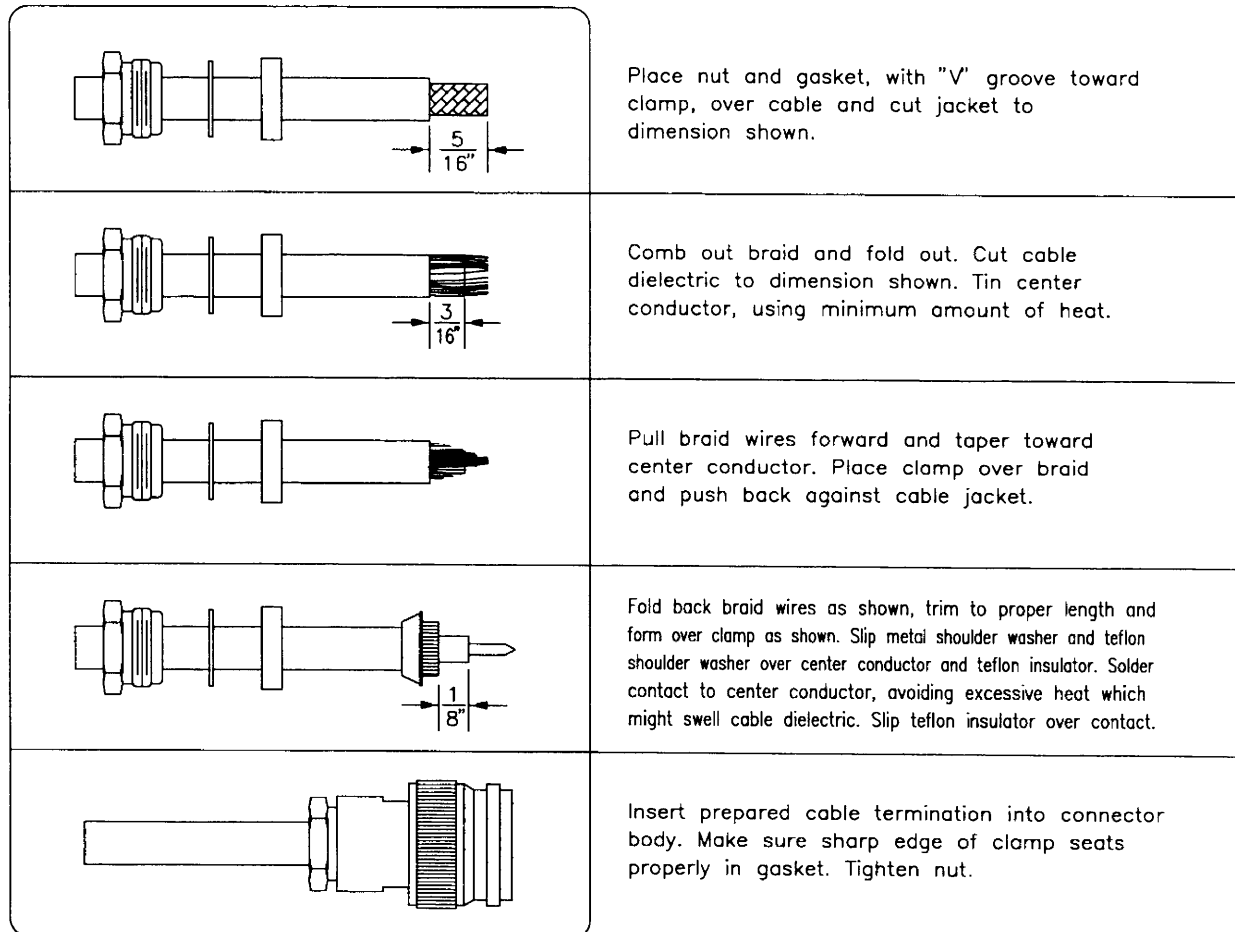
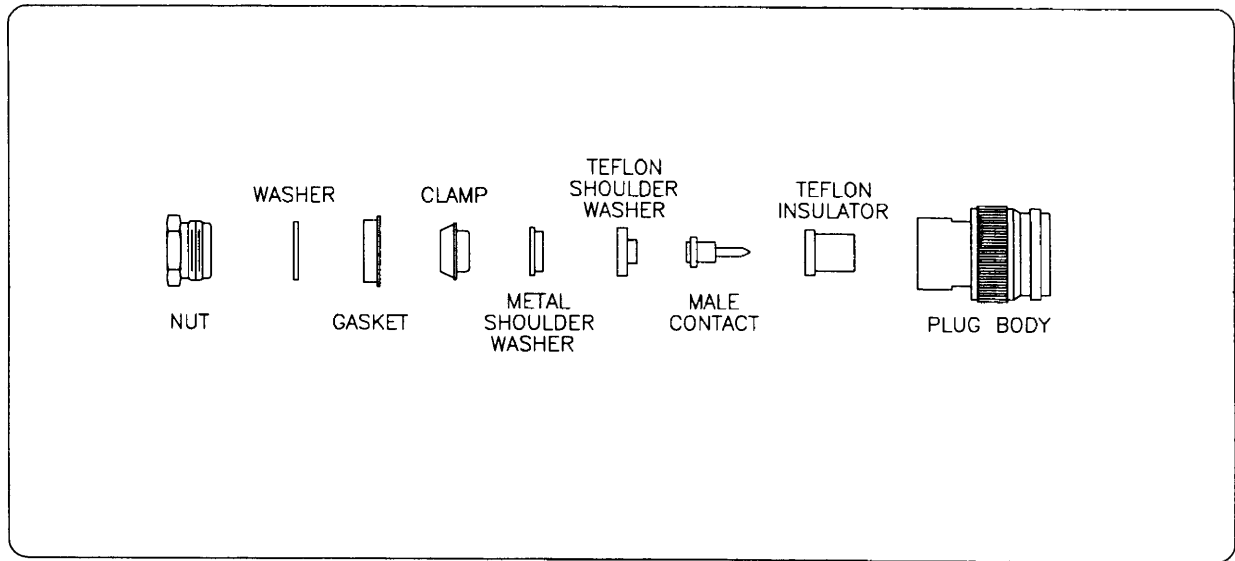
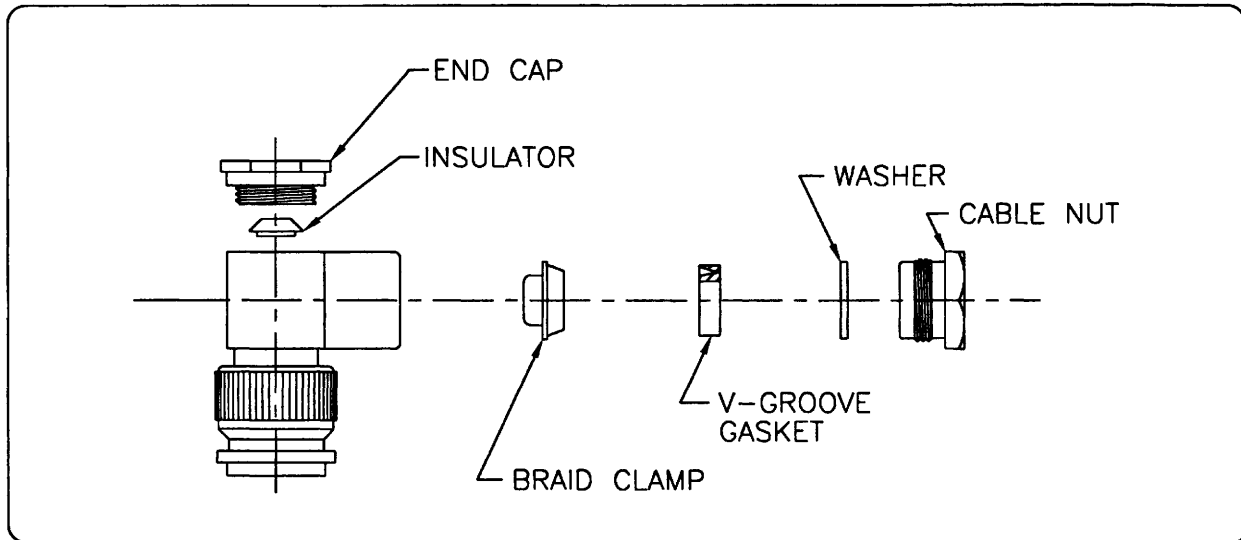
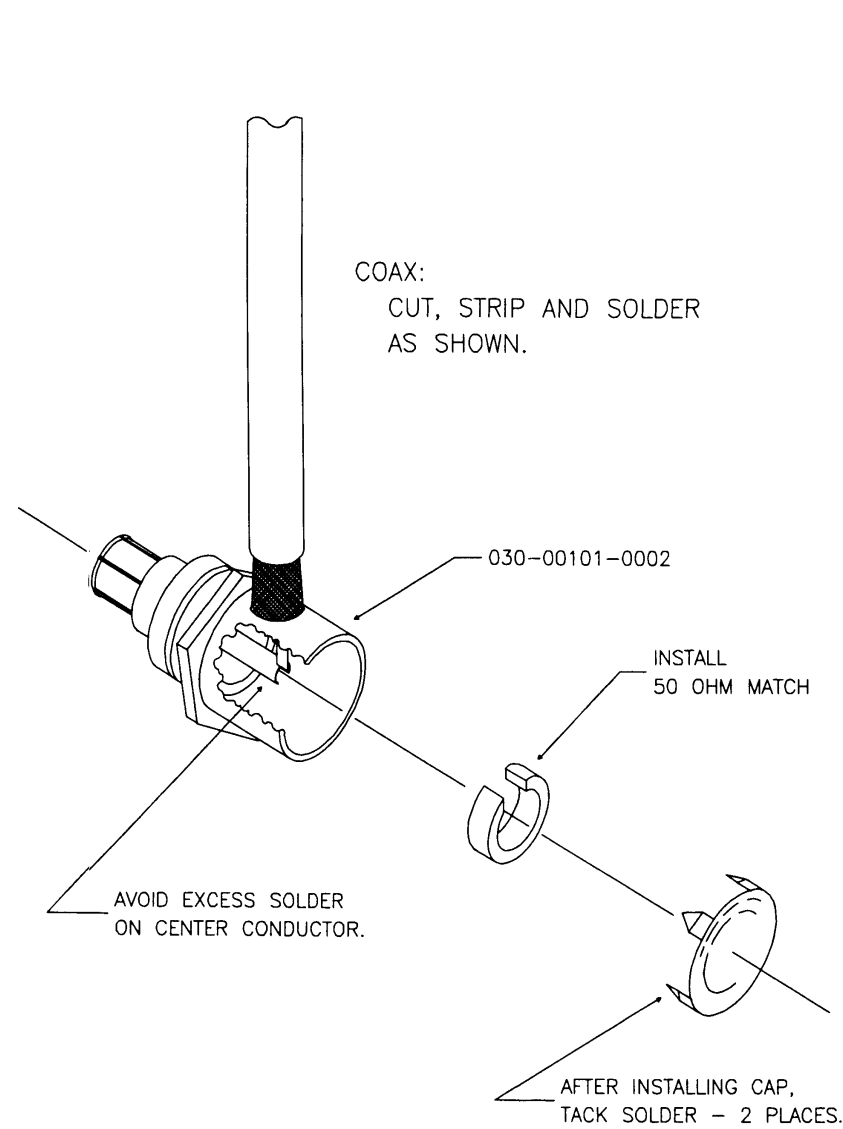

FIGURE 2-12A KA 91/92 TNC ANTENNA COAX / CONNECTOR ASSEMBLY
 (RG142B/U or RG400 - 0 to 40 FEET)
 (Straight Connector P/N 030-00134-0000)



	<p>Place nut and gasket, with "V" groove toward clamp, over cable and cut jacket to dimension shown.</p>
	<p>Comb out braid and fold out. Cut cable dielectric to dimension shown. Tin center conductor, using minimum amount of heat.</p>
	<p>Pull braid wires forward and taper toward center conductor. Place clamp over braid and push against outer jacket of cable.</p>
	<p>Fold back braid wires as shown, trim to proper length and form over clamp as shown.</p>
	<p>Insert prepared cable termination into connector body until center conductor is completely into slot of contact, tighten cable nut and solder center conductor. Insert insulator into connector body as shown in upper figure. Insert end cap and tighten completely.</p>

FIGURE 2-12B KA 91/92 TNC ANTENNA COAX / CONNECTOR ASSEMBLY
 (RG142B/U or RG400 - 0 to 40 FEET)
 (Right-Angle Connector P/N 030-00134-0001)



NOTES:

1. WHEN SOLDERING, AVOID APPLYING EXCESS HEAT TO CONNECTOR BODY, HEAT SINK SPRING CONTACTS, AND CENTER CONDUCTOR INSULATOR.

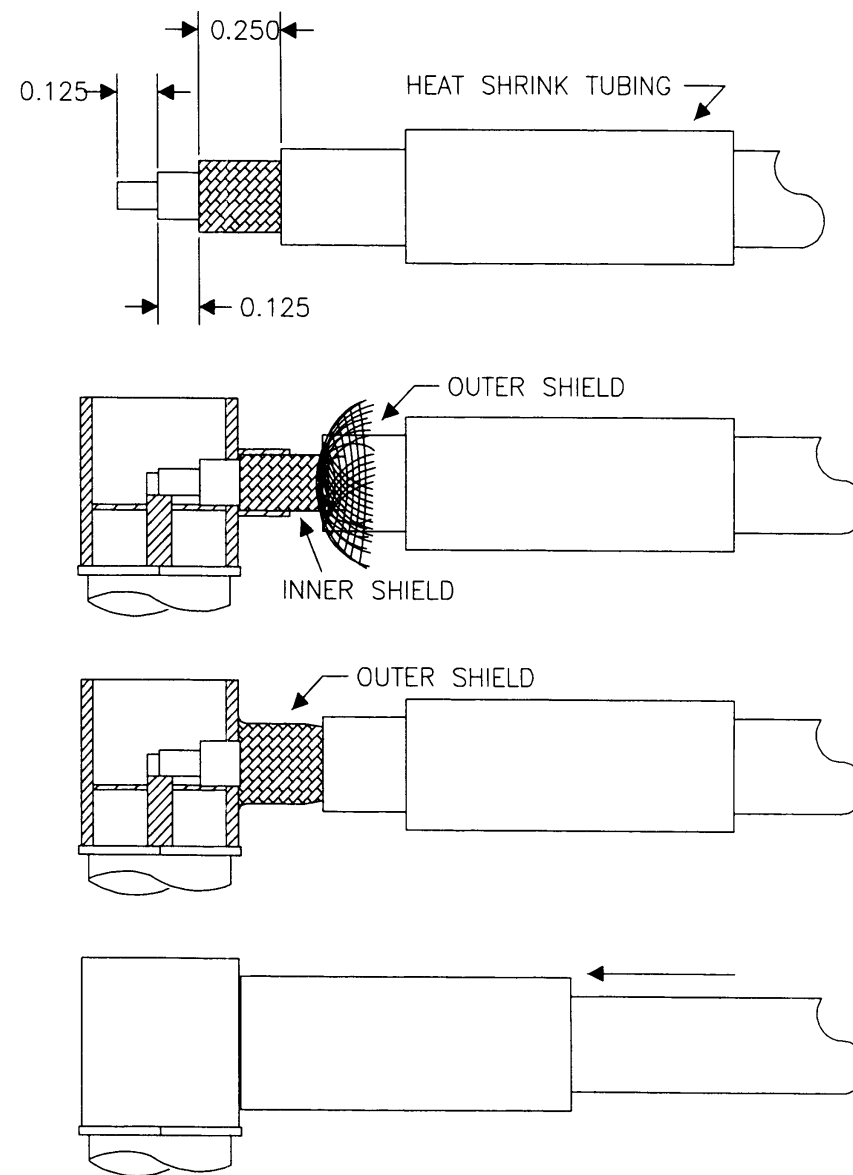

1. STRIP RG-142B/U (P/N 024-00002-0000) AND PLACE 1" HEAT SHRINK TUBING (P/N 150-00025-0010) OVER COAX.
2. SOLDER CENTER CONTACT AND SOLDER INNER SHIELD INSIDE. SEE NOTE 1.
3. SOLDER OUTER SHIELD OUTSIDE. SEE NOTE 1.
4. SLIDE HEAT SHRINK TUBING FORWARD (FLUSH WITH CONNECTOR) AND ADD HEAT TO SHRINK THE TUBING.

FIGURE 2-13 KA91/92 BMA ANTENNA COAX/CONNECTOR ASSEMBLY
(RG142 B/U or RG400 - 0 to 40 FEET)

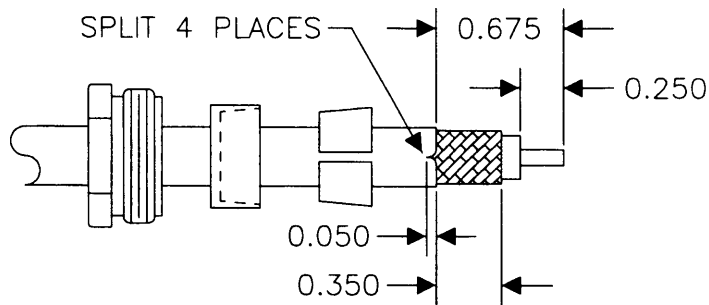

1. Place cable nut, bushing and braid clamp over outer jacket. Trim cable jacket, braid and dielectric to dimensions shown. Split outer jacket in 4 places (approx. 90° apart) to dimension. Lightly tin center conductor.

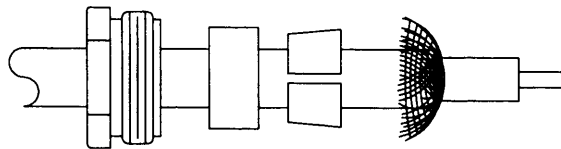

2. Fold back braid, foil and inner shield to expose dielectric.

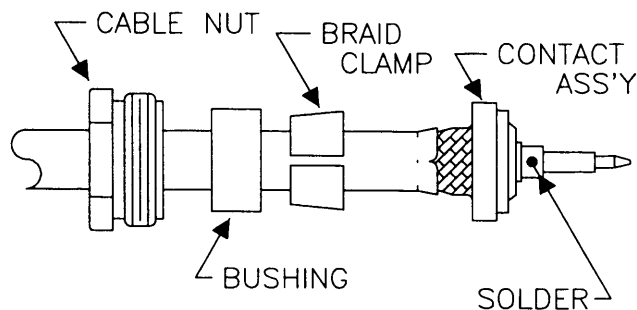

3. Slide contact assembly (pin or socket) between inner dielectric and foil shield. Make certain contact assembly is pushed on cable to flare outer jacket and center conductor is visible through inspection hole. Smooth shields back over contact assembly and solder center contact as shown.

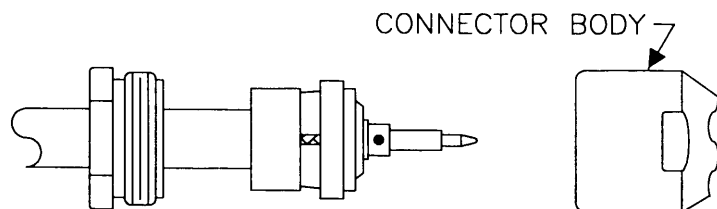

4. Push braid clamp and bushing forward over shield as far as possible. Slide cable nut over bushing and insert finished assembly into connector body. Tighten cable nut completely to seal cable assembly.

FIGURE 2-14 KA 91/92 TNC ANTENNA COAX / CONNECTOR ASSEMBLY
 0 to 80 FEET / 0 to 100 FEET
 (For Cable P/Ns 024-00071-0000 Rev. 0 / 024-00072-0000 Rev. 0)

THIS PAGE IS RESERVED.

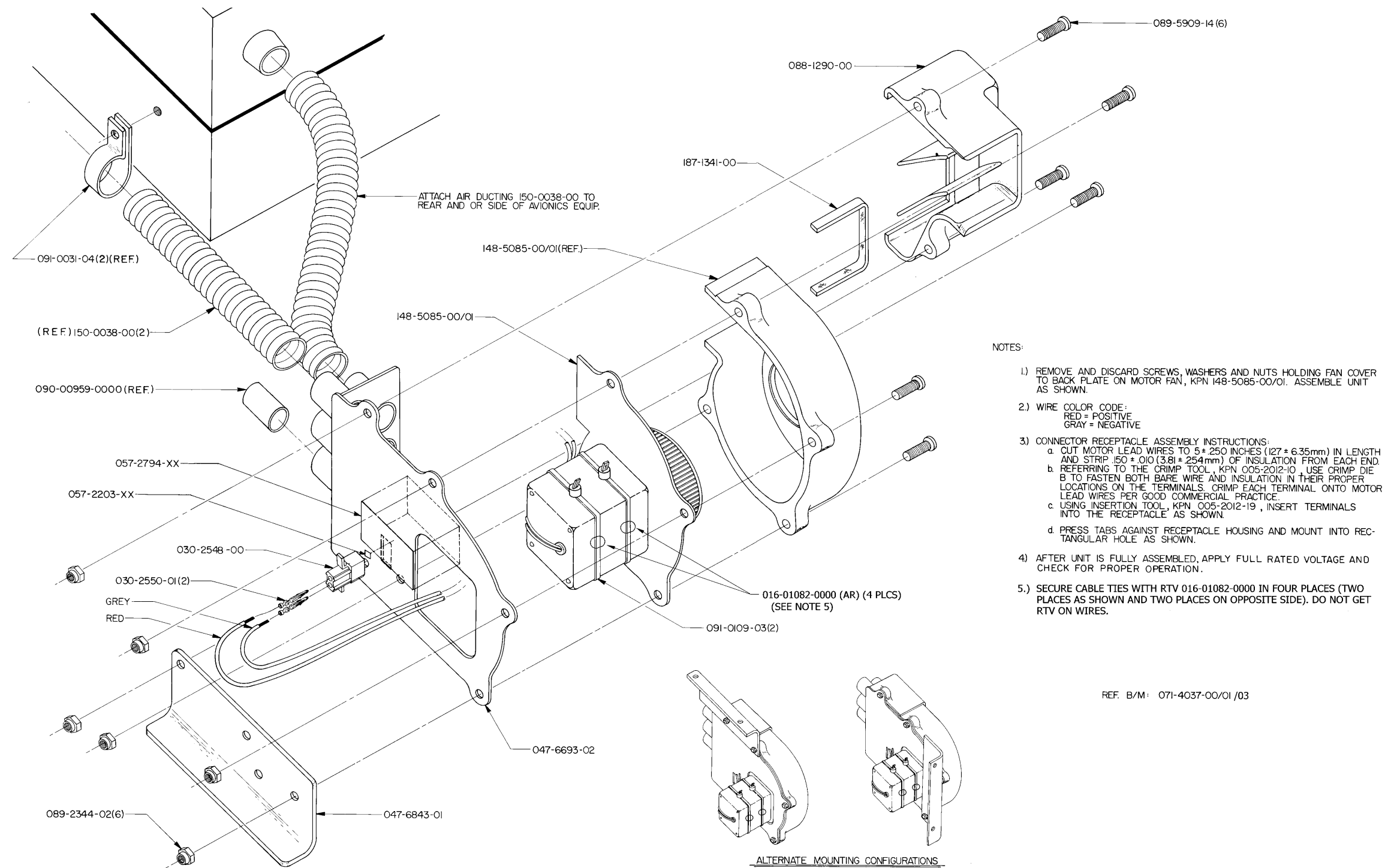

FIGURE 2-15 KA 33 P/N 071-4037-00 /01 FINAL ASSEMBLY
Dwg. No. 300-03256-0000 Rev. AA



FIGURE 2-16 KA 33 P/N 071-4037-00/01 OUTLINE AND MOUNTING
Dwg. No. 155-05574-0000 Rev. 5

INSTALLATION AND REMOVAL TOOLS (AVAILABLE FROM LCOMP)

TYPE	EATON PART NUMBER
CONNECTOR PIN CRIMP TOOL	58T-103
CONNECTOR PIN REMOVAL TOOL	58T-104
CONNECTOR PIN REMOVAL TOOL TIP	58T-105-2

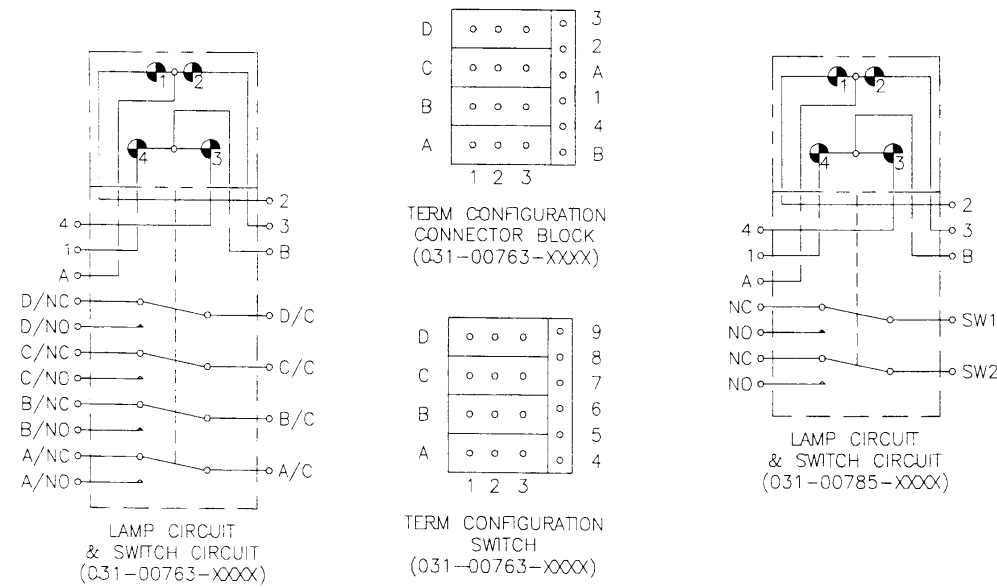
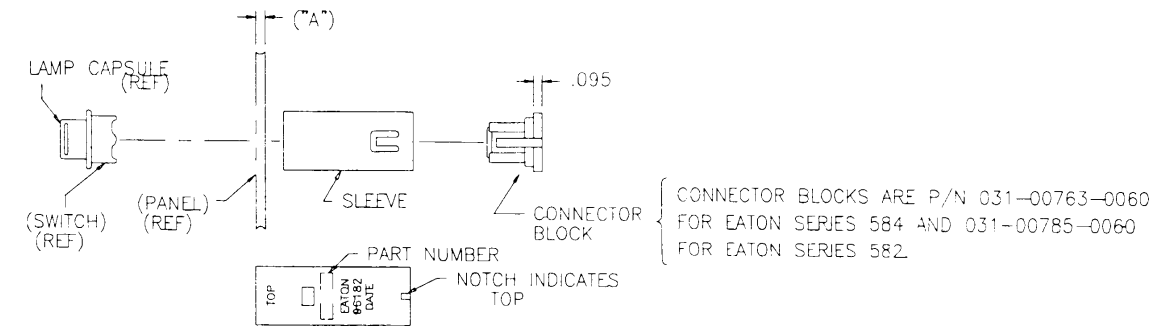

MOUNTING SLEEVES		
PANEL THICKNESS DIMENSION "A"	ALLIEDSIGNAL PART NUMBER	VENDOR PART NUMBER
.052" TO .072"	031-00763-0029	4686-29
.083" TO .103"	031-00763-0030	4686-30
.115" TO .135"	031-00763-0031	4686-31
USE THE ABOVE WITH EATON SERIES 584		
.052" TO .072"	031-00785-0029	4686-29
.083" TO .103"	031-00785-0030	4686-30
.115" TO .135"	031-00785-0031	4686-31
USE THE ABOVE WITH EATON SERIES 582		

THREE SLEEVES AND A CONNECTOR BLOCK ARE PROVIDED WITH EACH ANNUNCIATOR/SWITCH ASSEMBLY TO ACCOMMODATE A FULL RANGE OF PANEL THICKNESSES.

NOTES:

1. MOMENTARY SWITCH TRAVEL IS SUCH THAT THE CAPSULE IS FLUSH WITH, OR RECESSED INTO, THE BEZEL OF THE SWITCH BODY WHEN FULLY ACTUATED.
2. ALTERNATE ACTION SWITCH TRAVEL AND RETAINED POSITION ARE SUCH THAT THE CAPSULE IS FLUSH WITH, OR RECESSED INTO, THE BEZEL OF THE SWITCH BODY WHEN ACTUATED.
3. COMPLETE ANNUNCIATORS/SWITCHES ARE AVAILABLE FROM LCOMP. PARTS FOR CONVERSION OR REPAIR ARE ALSO AVAILABLE.

LCOMP Aerospace Controls
9214 Bond
Overland Park, KS 66214

TELEPHONE:
(913) 438-4848
(800) 821-2915
(913) 438-4839 (FAX)

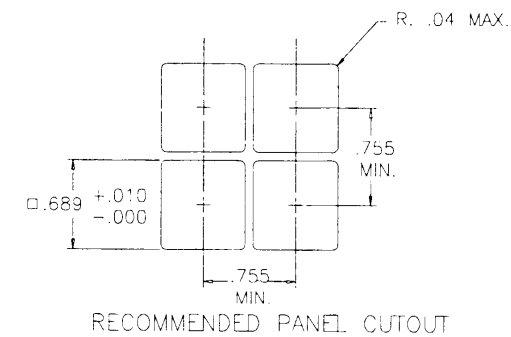
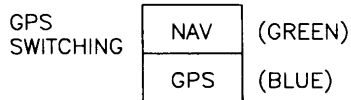
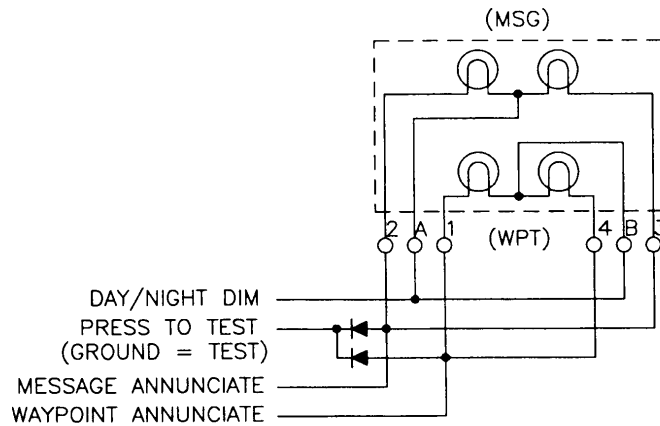

FIGURE 2-17 CUTLER-HAMMER SWITCH / ANNUNCIATOR MOUNTING



ANNUNCIATOR
 28 V -0505
 14 V -0762
 5 V -0506



SWITCH/ANNUNCIATOR
 28 V -0711
 14 V -0712
 5 V -0713

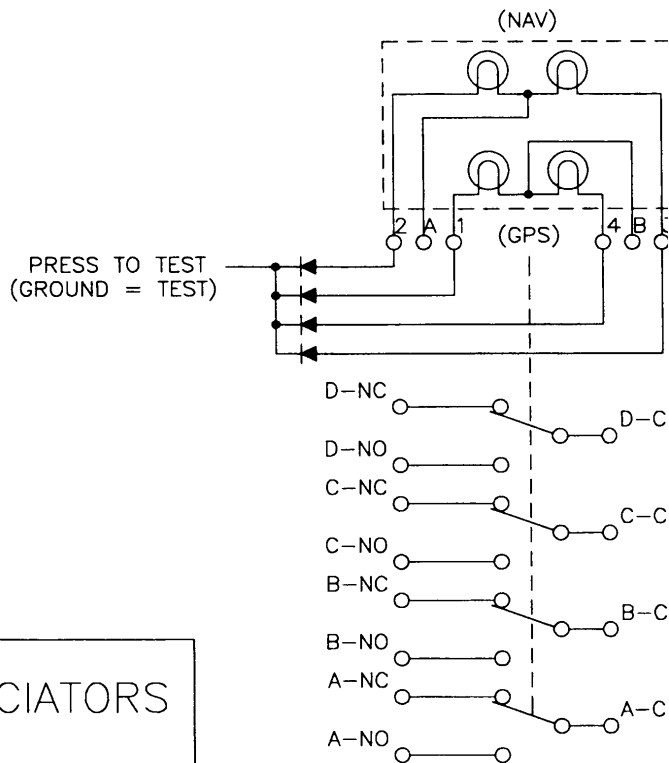

GPS SWITCHES/ANNUNCIATORS
 031-00763-XXXX

FIGURE 2-18 CUTLER-HAMMER SWITCH / ANNUNCIATOR INTERNAL SCHEMATIC
 Sheet 1 of 2

THIS PAGE IS RESERVED.

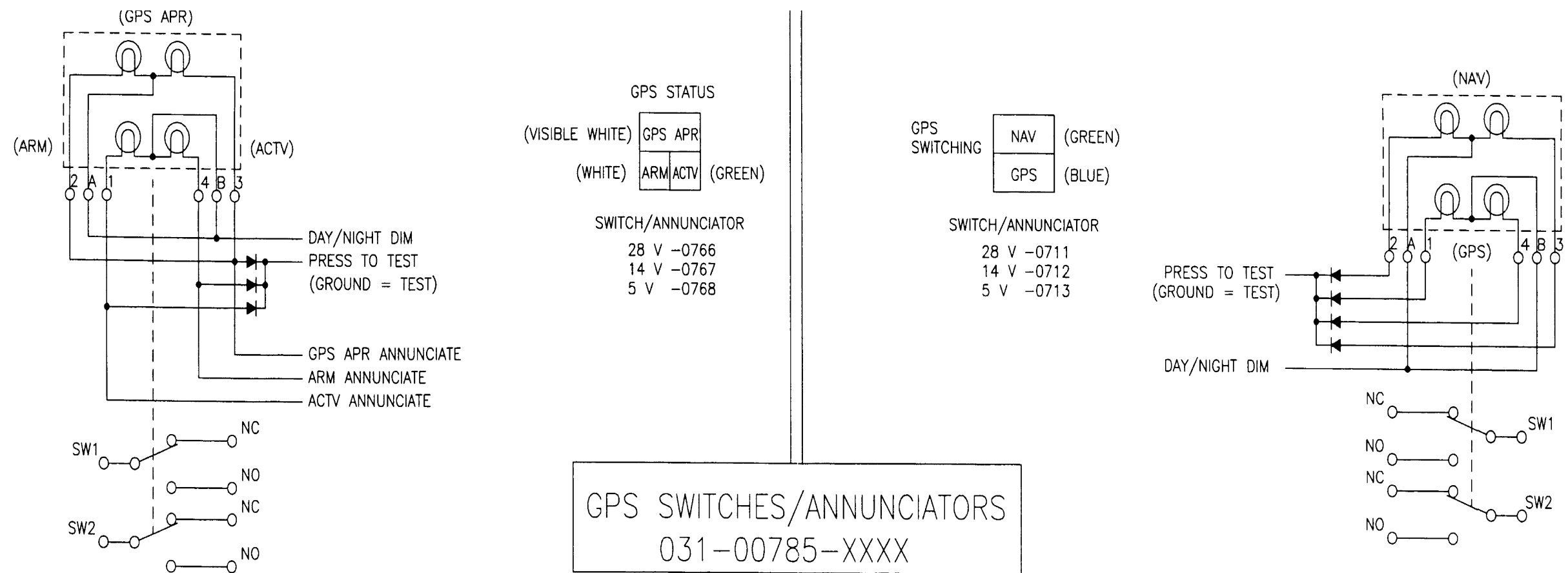
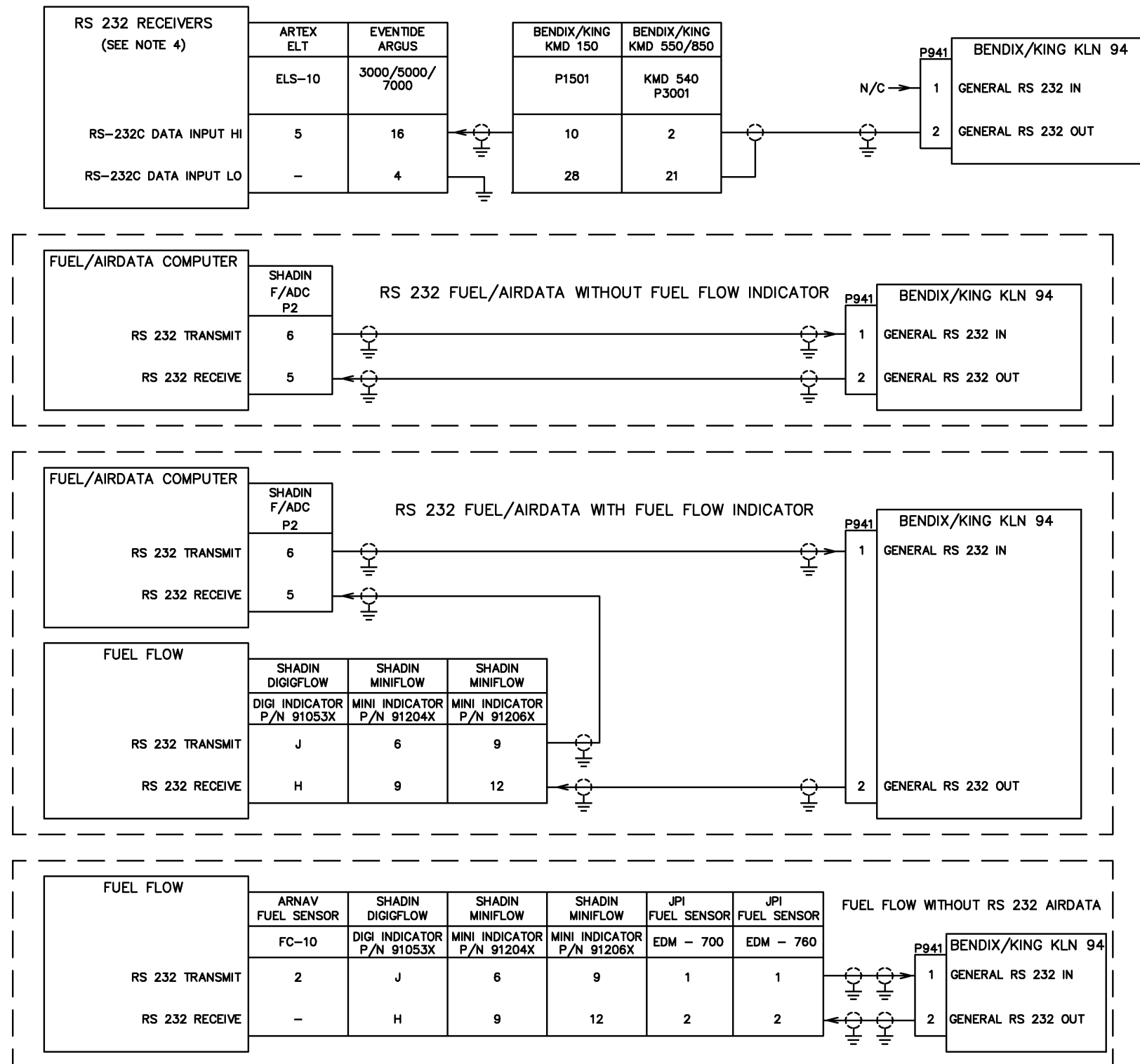

FIGURE 2-18 CUTLER-HAMMER SWITCH / ANNUNCIATOR INTERNAL SCHEMATIC
Sheet 2 of 2



NOTES:

1. LOWERCASE LETTER CONNECTOR PIN DESIGNATORS ARE SHOWN AS UNDERLINED UPPERCASE LETTERS.
2. ALL WRES ARE 24 AWG MINIMUM UNLESS OTHERWISE NOTED.
3. GENERAL RS 232 OUT CAN DRIVE SEVERAL INPUTS. ONLY ONE TRANSMITTER CAN BE CONNECTED TO GENERAL RS 232 IN AT A TIME.
4. RS 232 RECEIVERS MAY NOT BE USED AS THE PRIMARY FLIGHT DISPLAY FOR THE KLN 94.
5. CONNECT THESE SHIELD GROUNDS TO AIRCRAFT CHASSIS WITH AS SHORT A CONDUCTOR AS PRACTICAL.

FIGURE 2-19 KLN 94 SERIAL RECEIVERS & TRANSMITTERS INTERCONNECT
Dwg. No. 155-01732-0000 Rev. B

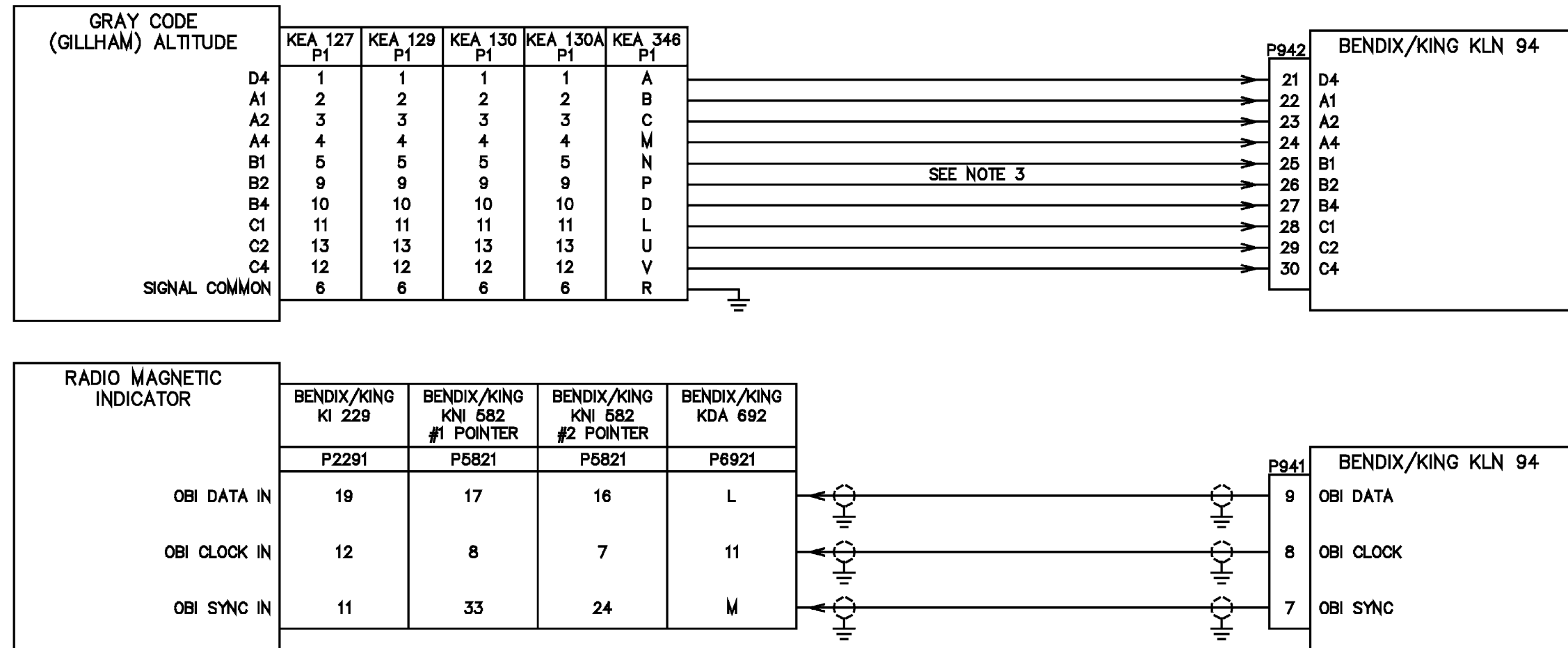

NOTES:

1. LOWERCASE LETTER CONNECTOR PIN DESIGNATORS ARE SHOWN AS UNDERLINED UPPERCASE LETTERS.
2. ALL WIRES ARE 24 AWG MINIMUM UNLESS OTHERWISE NOTED.
3. SOME RECEIVERS OF THE ALTITUDE ENCODER DO NOT HAVE INTERNAL ISOLATION DIODES TO PREVENT THE UNIT FROM PULLING THE ENCODER LINES TO GROUND WHEN THE UNIT IS OFF. SOME TRANSPONDERS AND OTHER DEVICES DO NOT HAVE THE INTERNAL DIODES. THESE UNITS REQUIRE A DIODE TO BE ADDED TO THE INSTALLATION HARNESS FOR EVERY ENCODER LINE. THE DIODES ARE INSERTED AT THE CONNECTION TO THE UNIT THAT DOES NOT HAVE INTERNAL DIODES. THE ANODE IS ON THE RECEIVING UNITS SIDE AND THE CATHODE IS ON THE ENCODER SIDE. A 1N4007, OUR PART NUMBER 007-06048-0000, MEETS HIRF AND LIGHTNING REQUIREMENTS. A SET OF DIODES IS REQUIRED FOR EACH UNIT WITHOUT INTERNAL DIODES.
4.  CONNECT THESE SHIELD GROUNDS TO AIRCRAFT CHASSIS WITH AS SHORT A CONDUCTOR AS PRACTICAL.

FIGURE 2-20 KLN 94 ALTITUDE & RMI / OBI INTERCONNECT
Dwg. No. 155-01732-0001 Rev.-

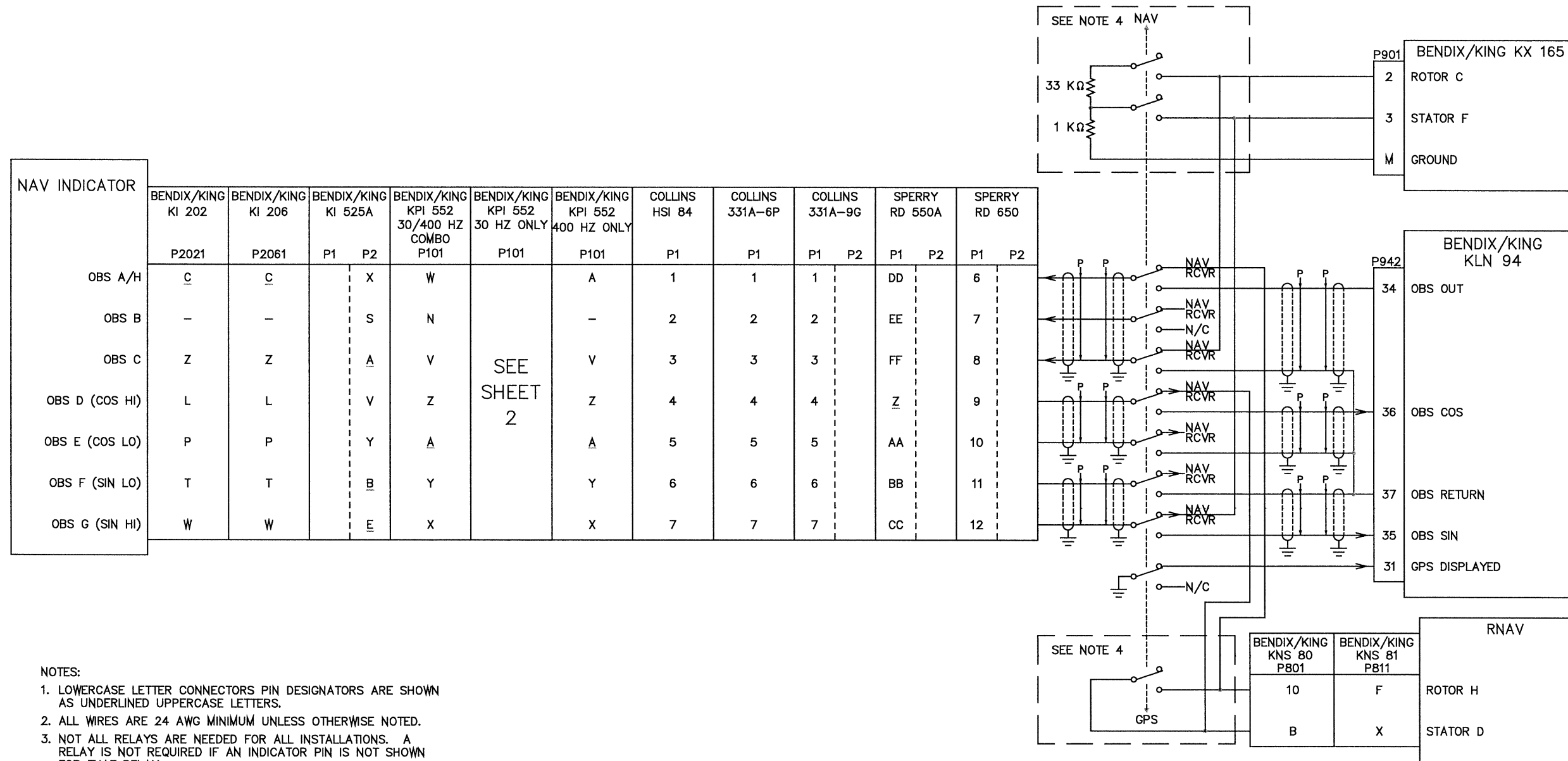
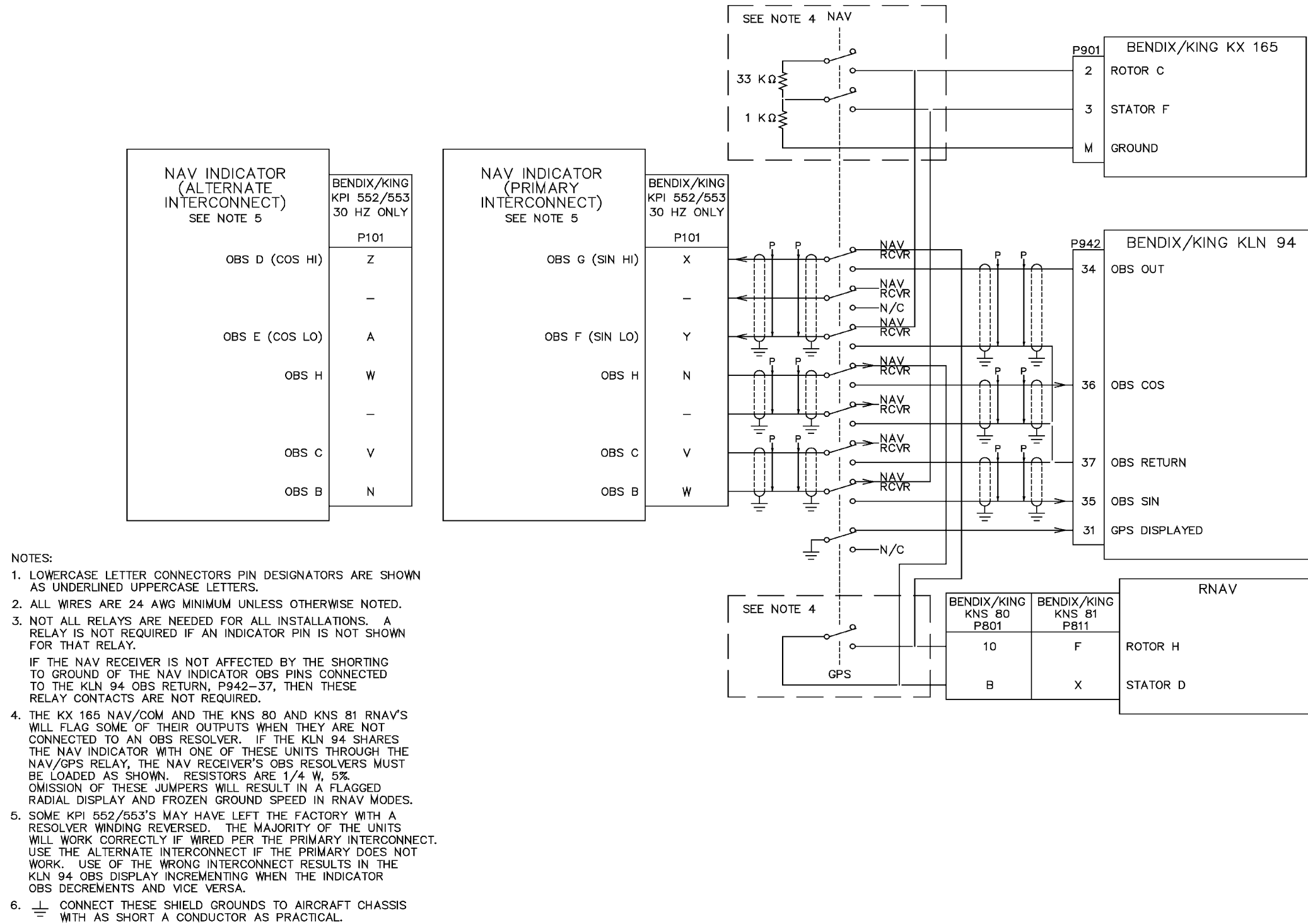

FIGURE 2-22 KLN 94 OBS RESOLVER INTERCONNECT
Dwg. No. 155-01732-0003 Rev.-
Sheet 1 of 2



- NOTES:
1. LOWERCASE LETTER CONNECTORS PIN DESIGNATORS ARE SHOWN AS UNDERLINED UPPERCASE LETTERS.
 2. ALL WIRES ARE 24 AWG MINIMUM UNLESS OTHERWISE NOTED.
 3. NOT ALL RELAYS ARE NEEDED FOR ALL INSTALLATIONS. A RELAY IS NOT REQUIRED IF AN INDICATOR PIN IS NOT SHOWN FOR THAT RELAY.
IF THE NAV RECEIVER IS NOT AFFECTED BY THE SHORTING TO GROUND OF THE NAV INDICATOR OBS PINS CONNECTED TO THE KLN 94 OBS RETURN, P942-37, THEN THESE RELAY CONTACTS ARE NOT REQUIRED.
 4. THE KX 165 NAV/COM AND THE KNS 80 AND KNS 81 RNAV'S WILL FLAG SOME OF THEIR OUTPUTS WHEN THEY ARE NOT CONNECTED TO AN OBS RESOLVER. IF THE KLN 94 SHARES THE NAV INDICATOR WITH ONE OF THESE UNITS THROUGH THE NAV/GPS RELAY, THE NAV RECEIVER'S OBS RESOLVERS MUST BE LOADED AS SHOWN. RESISTORS ARE 1/4 W, 5%. OMISSION OF THESE JUMPERS WILL RESULT IN A FLAGGED RADIAL DISPLAY AND FROZEN GROUND SPEED IN RNAV MODES.
 5. SOME KPI 552/553'S MAY HAVE LEFT THE FACTORY WITH A RESOLVER WINDING REVERSED. THE MAJORITY OF THE UNITS WILL WORK CORRECTLY IF WIRED PER THE PRIMARY INTERCONNECT. USE THE ALTERNATE INTERCONNECT IF THE PRIMARY DOES NOT WORK. USE OF THE WRONG INTERCONNECT RESULTS IN THE KLN 94 OBS DISPLAY INCREMENTING WHEN THE INDICATOR OBS DECREMENTS AND VICE VERSA.
 6. CONNECT THESE SHIELD GROUNDS TO AIRCRAFT CHASSIS WITH AS SHORT A CONDUCTOR AS PRACTICAL.

FIGURE 2-23 KLN 94 INTERCONNECT
Dwg. No. 155-01732-0003 Rev.-
Sheet 2 of 2

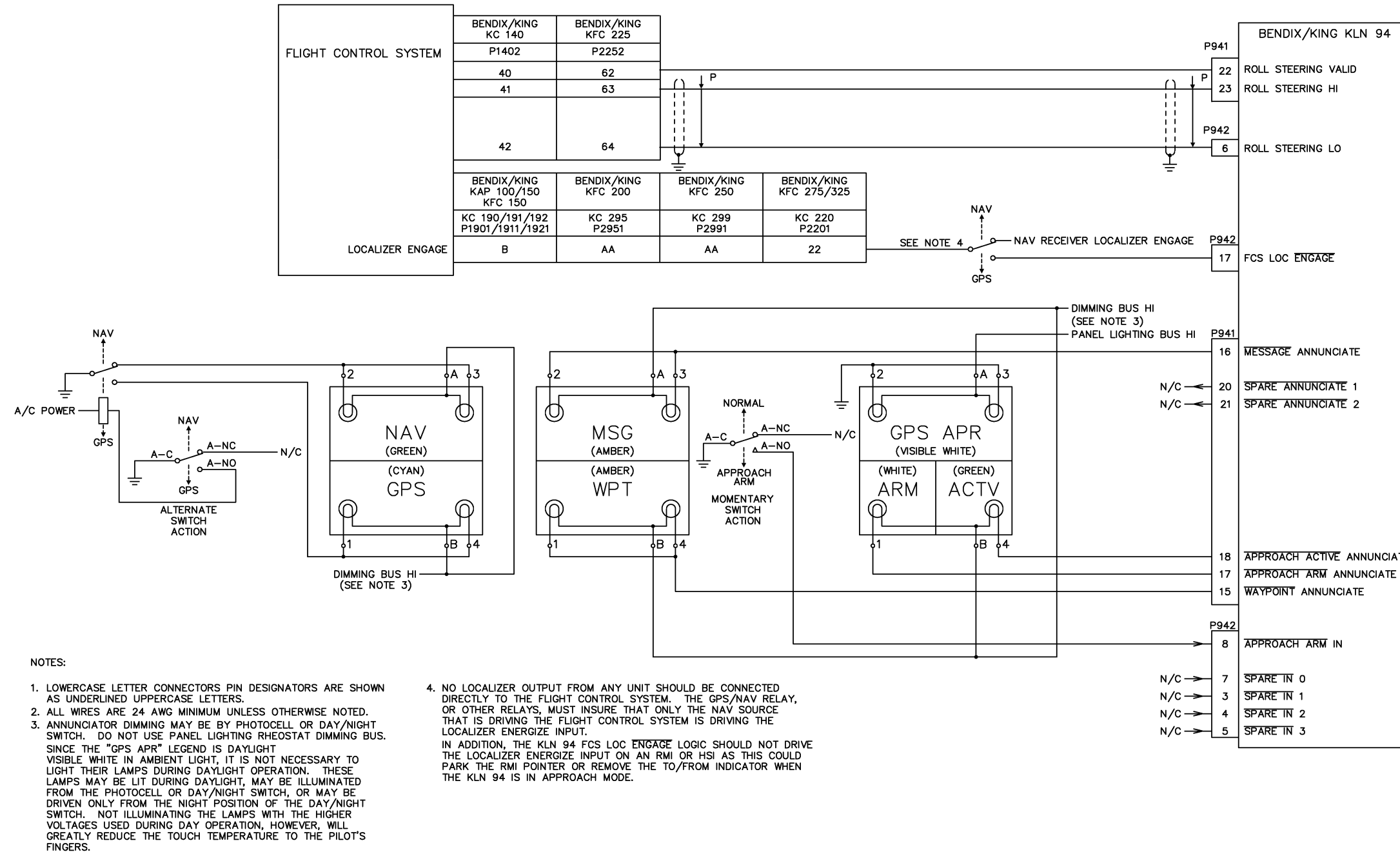
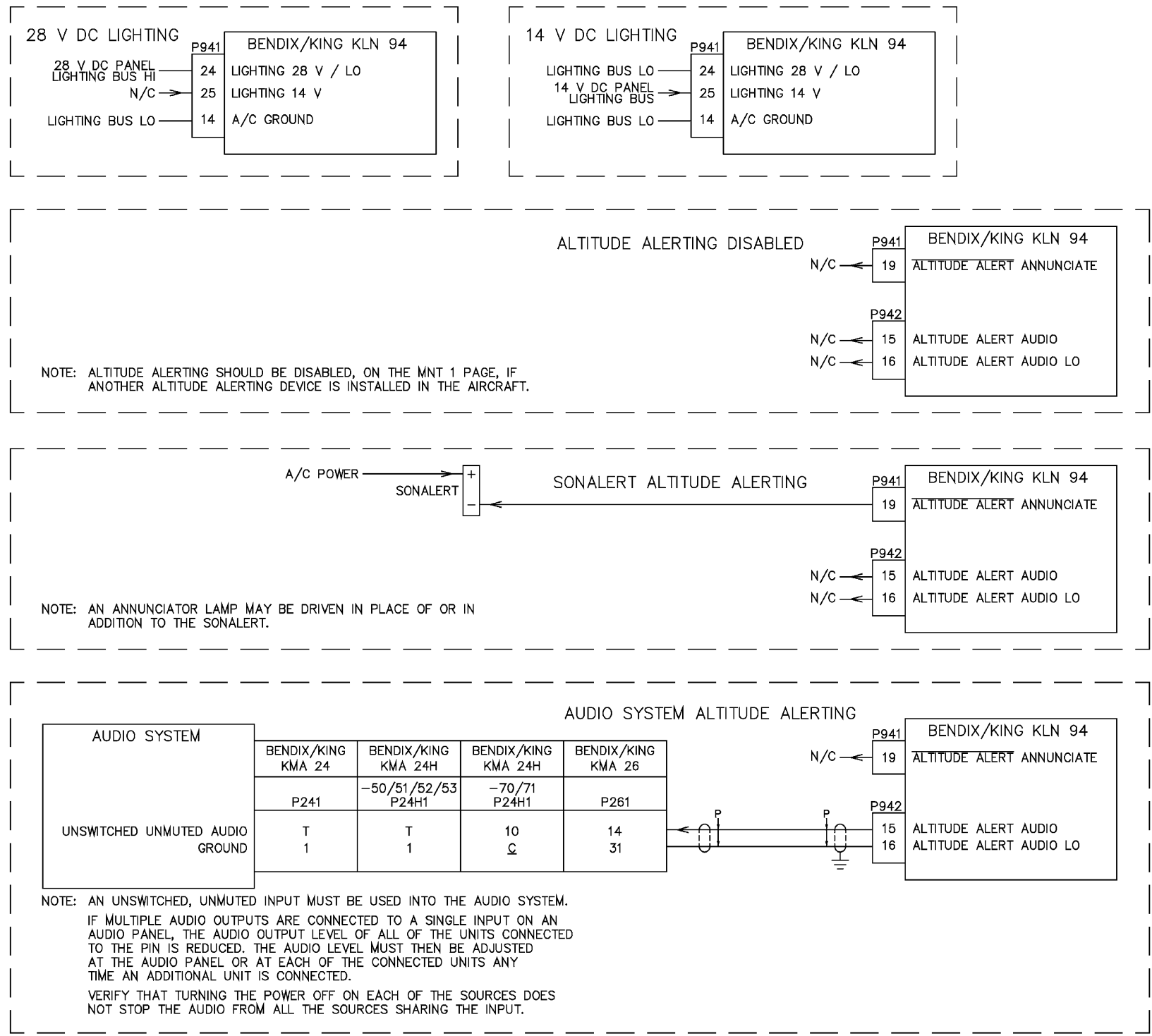
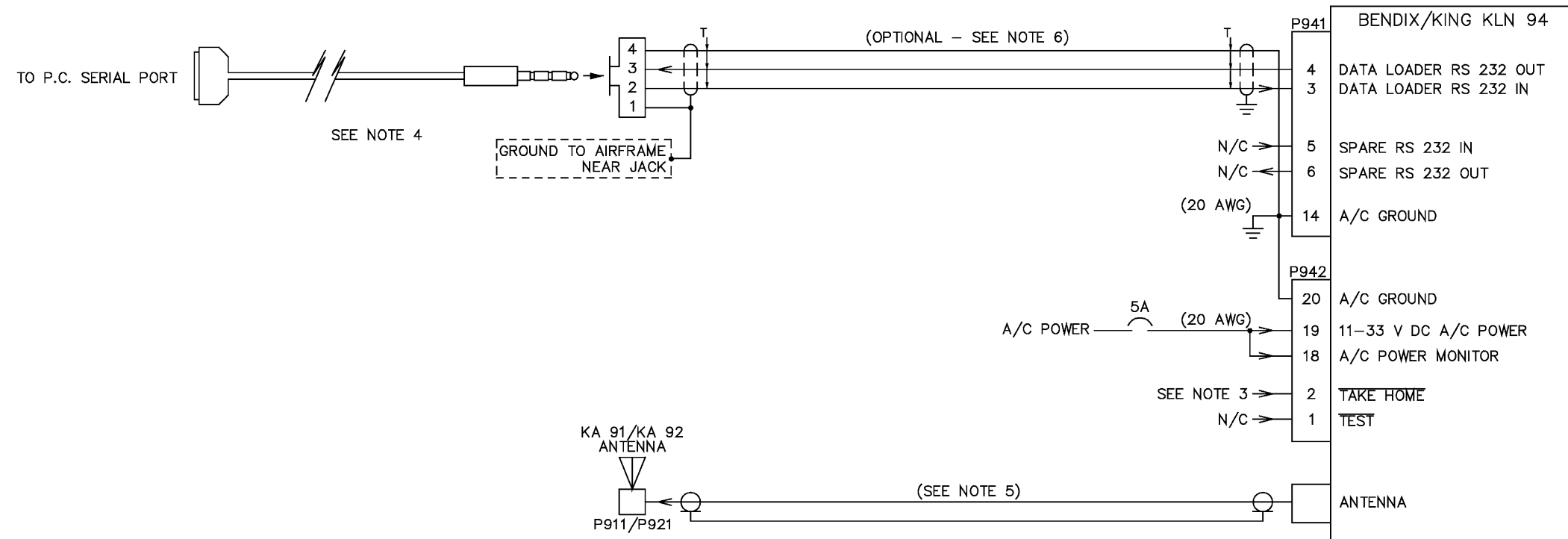

FIGURE 2-24 KLN 94 FCS & EXT. ANNUNC. INTERCONNECT
Dwg. No. 155-01732-0004 Rev. A



- NOTES:
1. LOWERCASE LETTER CONNECTOR PIN DESIGNATORS ARE SHOWN AS UNDERLINED UPPERCASE LETTERS.
 2. ALL WIRES ARE 24 AWG MINIMUM UNLESS OTHERWISE NOTED.
 3. $\underline{\text{—}}$ CONNECT THESE SHIELD GROUNDS TO AIRCRAFT CHASSIS WITH AS SHORT A CONDUCTOR AS PRACTICAL.

FIGURE 2-25 KLN 94 BACKLIGHTING & ALT. ALERTING INTERCONNECT
Dwg. No. 155-01732-0005 Rev.-



NOTES:

1. LOWERCASE LETTER CONNECTOR PIN DESIGNATORS ARE SHOWN AS UNDERLINED UPPERCASE LETTERS.
2. ALL WIRES ARE 24 AWG MINIMUM UNLESS OTHERWISE NOTED.
3. THIS PIN MUST ALWAYS BE OPEN WHEN THE UNIT IS USED FOR NAVIGATION. THIS PIN IS CONNECTED TO GROUND TO PLACE THE UNIT IN THE TAKE HOME FLIGHT SIMULATION MODE.
4. PART OF 050-03213-0000 INTERFACE KIT.
5. WIRE TYPE VARIES WITH WIRE LENGTH. REFER TO ANTENNA INSTALLATION CONSIDERATIONS SECTION OF INSTALLATION MANUAL FOR DETAILS.
6. IT IS NOT NECESSARY, BUT IT IS POSSIBLE, TO INSTALL THIS PANEL MOUNTED DATA LOADER CONNECTOR. THE KLN94 HAS THE SAME JACK MOUNTED IN ITS FRONT BEZEL. THE BEZEL MOUNTED JACK IS WIRED IN PARALLEL WITH THE DATA LOADER PINS ON P941. EITHER JACK MAY BE USED INDIVIDUALLY BUT BOTH JACK MAY NEVER BE CONNECTED AT THE SAME TIME TO A DATA SOURCE. THIS CONNECTIONS ARE COMMON TO KLN89/89B INSTALLATIONS THAT WERE UPGRADED TO KLN94.
7. \perp CONNECT THESE SHIELD GROUNDS TO AIRCRAFT CHASSIS WITH AS SHORT A CONDUCTOR AS PRACTICAL.

FIGURE 2-26 KLN 94 PC LOADER & ANTENNA INTERCONNECT
Dwg. No. 155-01732-0006 Rev.-

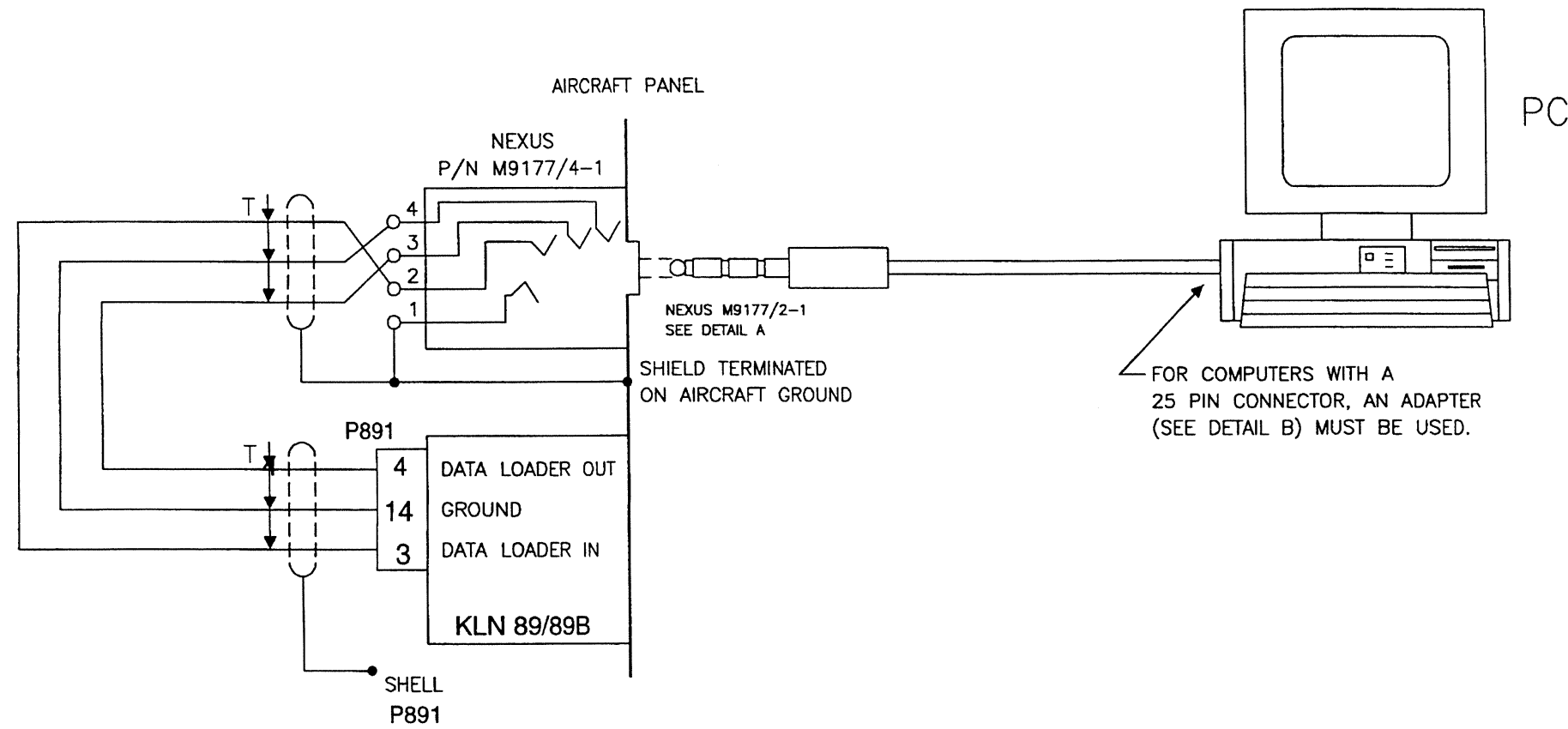

NOTE

IT IS NOT NECESSARY, BUT IT IS POSSIBLE, TO INSTALL THIS PANEL MOUNTED DATA LOADER CONNECTOR. THE KLN 94 HAS THE SAME JACK MOUNTED IN ITS FRONT BEZEL. THE BEZEL MOUNTED JACK IS WIRED PARALLEL WITH THE DATA LOADER PINS ON P891. EITHER JACK MAY BE USED INDIVIDUALLY BUT BOTH JACKS MAY NEVER BE CONNECTED AT THE SAME TIME TO A DATA SOURCE. THESE CONNECTIONS ARE COMMON TO KLN 89/89B INSTALLATIONS THAT WERE UPGRADED TO KLN 94.

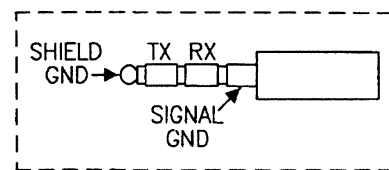

DETAIL A

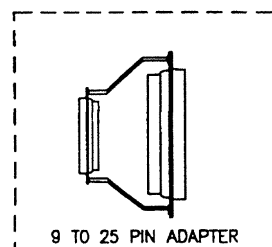

DETAIL B

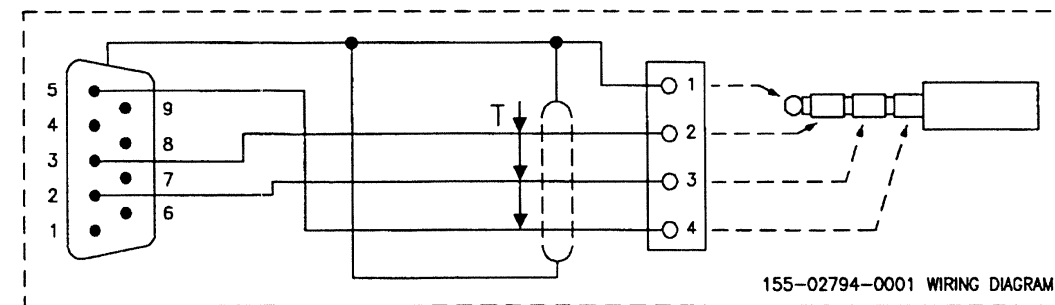

DETAIL C

FIGURE 2-27 KLN 94 DATA LOADER / PC INTERFACE

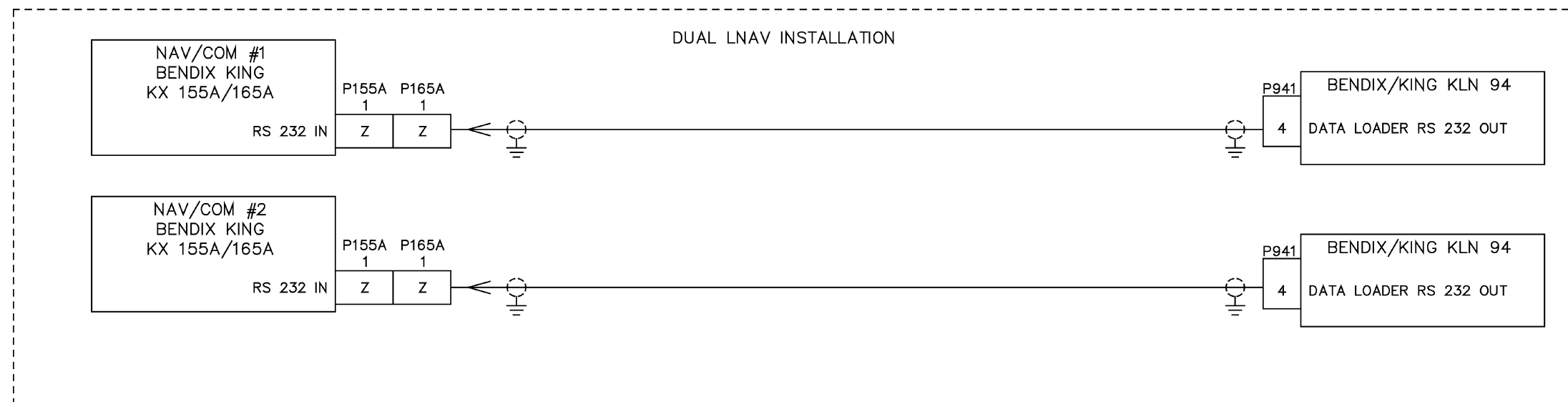
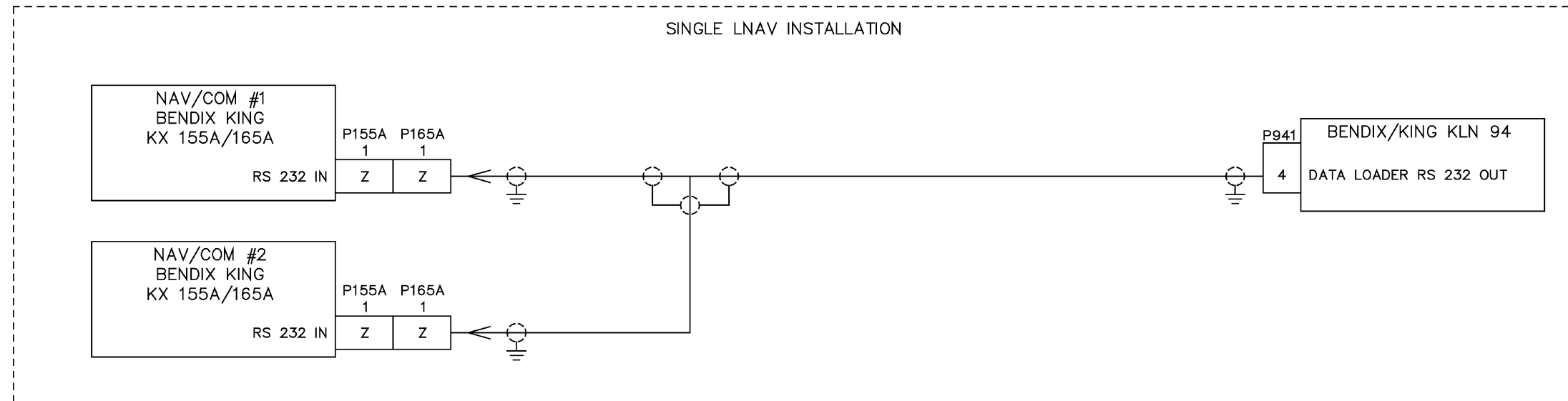

NOTES:

1. ALL WIRES ARE 24 AWG MINIMUM UNLESS OTHERWISE NOTED.
2. CONNECT THESE SHIELD GROUNDS TO AIRCRAFT CHASSIS WITH AS SHORT A CONDUCTOR AS PRACTICAL.

FIGURE 2-28 KLN 94 QUICKTUNE INTERCONNECT
Dwg. No. 155-01732-0007 Rev.-

2.4 POST INSTALLATION CHECK OUT INFORMATION

2.4.1 Maintenance Pages

As part of every KLN 94 installation it is necessary to enter the Maintenance (MNT) pages in order to configure the unit properly for the specific installation. Electronically configuring the units replaces the need of installing strapping or configuration wires in the harness. This makes it easier to configure the unit at the time of initial installation and also later on if changes are made to the aircraft such as the later addition of a fuel management system, air data system, or reconfigure from VFR to IFR.

This configuration data is stored both in the external configuration module (mounted in the back plate of the mounting tray) and in memory internal to the KLN 94. When the KLN 94 is initially shipped from the factory, the configuration data is set to the same default values/status in both the external configuration module and the units internal memory. The initial defaults are specified below. When the Maintenance pages are entered and changes made to the configuration data, the changes are stored both in the external configuration module and the internal memory. If the configuration data differs in the external configuration module from the units internal memory, the external configuration module data is automatically used. Differences could occur if after configuring the KLN 94 the initial unit was removed and a second unit inserted into the rack. For example, if the KLN 94 is initially configured correctly and a loaner unit is later installed in the aircraft, the external configuration module would ensure that the proper configuration data was used. The external configuration module is part of the installation kit and should be utilized in every installation to make sure that proper operation occurs regardless of the unit that may later be inserted into the mounting tray.

To enter the Maintenance pages, the MSG button must be depressed before the unit is turned and held. Hold the MSG button down and watch for a flash in the "Earth with Satellites" picture. Continue to depress the MSG button for 10 seconds (+- 2 seconds) after the flash of the "Earth with Satellites". During that 10 seconds, you will see the picture change from monochrome to color. At the end of the 10 second period, release the MSG button for 1 second and momentarily press the MSG button again. After about a 15 second period the "Earth with Satellites" picture will change to a MNT Page. After entering the Maintenance pages if the configuration data is different between the external module and the units internal memory, the following page is displayed (this page will not be displayed if they are the same):

CONFIGURATION

1. Copy Module to Unit?
 2. Copy Unit to Module?
- Select: 1 OK?

If you wish to copy the configuration data from the external configuration module to the unit's internal memory or if you plan to manually change the configuration data, simply press the ENT button.

If you wish to copy the configuration data from the unit's internal memory to the external module, turn the large outer knob counterclockwise to position the flashing cursor over the 1. Turn the small inner knob to select a 2. Turn the large outer knob one step clockwise to position the cursor back over the OK? and then press the ENT button.

2.4.1.1 Maintenance 1 (MNT 1) Pages

The MNT+1 page is now displayed. There are three MNT+1 pages. The + sign indicates that there is more than one MNT 1 page. The first MNT 1 page has the following selection choices and format:

1. Whether the unit is certified as IFR or VFR.
2. Whether the unit is certified for IFR enroute/terminal use only or for both enroute/terminal and non-precision approach.
3. Whether the altitude alerting feature is enabled or disabled. If the aircraft has another source of altitude alerting such as that associated with a flight control preselector, this feature should be disabled.

First MNT +1 Page Format	Selection Choices	Default
IFR/VFR: IFR	IFR or VFR	VFR
IFR Apr/Enr: Apr	Apr or Enr (blank if line one above is VFR)	Enr
ALT alt: Enabled	Enabled or Disabled	Disabled

To change a selection:

Press the CRSR button to bring the flashing cursor on the screen. Turn the larger outer knob to position the cursor over the desired selection. Turn the small inner knob to change the selection. Make any additional changes on this page at this time. When finished, press the CRSR button to turn off the cursor.

To select different MNT pages:

Turn the small inner knob (the flashing cursor must be off the page. If it is on, press the CRSR button to turn it off). Select the second MNT+1 page.

The second MNT+1 page has the following selection choices and format. Changes are made using the CRSR button and concentric knob as described above.

1. Whether the KLN 94 is interfaced with a fuel management system.
2. Whether the fuel management system includes it own control/indicator used to enter fuel quantity. (Not a choice if there is no fuel management system).
3. What is the full fuel quantity of the aircraft. (Not a choice if there is no fuel management system or if the fuel management system has its own control/indicator used to enter fuel quantity).

Second MNT +1 Page Format	Selection Choices	Default
Installed Equipment		
Fuel Mgt Sys: Y	Y or N for yes or no	N
Fuel Mgt Ind: N	Y or N (this line blank if N is selected above)	N
Full Fuel: 0064	0000 to 9999 (this line blank if no fuel mgt sys or if fuel mgt sys has its own control/indicator)	0000

The third MNT+1 page has the following selection choices and format.

1. Whether the KLN 94 is installed with an air data computer.
2. Whether the KLN 94 is installed with a back-up emergency battery (not available from Honeywell).
3. Below what aircraft bus voltage should the back-up battery be used. (Not a choice if there is no emergency battery).

Third MNT +1 Page Format	Selection Choices	Default
Installed Equipment		
232 Air Data: Y	Y or N for yes or no	N
Emerg Bat: Y	Y or N for yes or no	N
Use Bat: 10.2 V	0-33 V (this line blank if no emerg bat)	10.2 V

2.4.1.2 Maintenance 2 (MNT 2) Page

The MNT 2 page displays total hours of operation and number of power cycles on the KLN 94 and is not configurable.

2.4.1.3 Maintenance 3 (MNT 3) Page

The MNT 3 page is used to calibrate the OBS setting of the aircraft’s HSI or CDI to the KLN 94 so that the KLN 94 reads the value the pilot selects on the HSI or CDI. It is necessary to configure this page only if the KLN 94 is interfaced to an HSI or CDI resolver such that the KLN 94 is able to read the course selected on the HSI or CDI. To calibrate the OBS:

1. Select a course using the course select/OBS knob on the HSI or OBS that is interfaced with the KLN 94. It is suggested that a course increment of 10 degrees (example 10, 150, 270, etc.) be used so that the course can be selected as precisely as possible.

2. Press the CRSR button to turn on the cursor.
3. Use the small inner knob to select the exact course that is selected on the HSI or CDI in step 1 above.
4. Adjust the HSI or CDI to another course which is not 180° away from the original course, and verify the correct course is displayed within 2°. If not, the OBS resolver interface may be miswired.
5. Press the CRSR button to turn off the cursor. The calibration is now complete.

2.4.1.4 Maintenance 4 (MNT 4) Page

The MNT 4 page is used to set the bus monitor voltage and alert delay so that if the aircraft's charging system were to fail (i.e. generator/alternator failure) the pilot would be given timely notification of the failure. The alert delay is selected so that momentary voltage drops which could be caused by such things as cycling the aircraft's gear or flaps do not cause nuisance notifications to the pilot. When the bus voltage falls below the selected alert voltage for the selected alert delay time the unit notifies the pilot with the following message that is displayed on the message page:

Low Bus Voltage
Check Charging System

This Power Monitor feature can be turned on and off by the pilot on the SET 9 page but actual configuration can only be done from the MNT 4 page. The SET 9 page displays to the pilot the actual bus voltage to the KLN 94 as well as the alert voltage and alert delay that have been configured on the MNT 4 page. Changes are made to the MNT 4 page using the CRSR button and the concentric knobs as described in [Section 2.4.1.1](#).

The MNT 4 page has the following format and choices:

MNT 4 Page Format	Selection Choices	Default
Bus Monitor		
Alert Volt 12.8 V	0.0 - 33.0 V	10.0 V
Alert Delay 15 S	0 - 99 seconds	15 S

The following procedure is suggested as a means of determining what voltage to use for the alert voltage. Cycle power to the KLN 94 to exit the Maintenance pages. View the SET 9 page to determine the actual voltage being supplied to the KLN 94 while the engine is running (alternator/generator supplying the bus voltage). You may want to do this with the engine at idle so that you see the lowest possible voltage supplied by the alternator/ generator. Next, determine the actual voltage being supplied to the KLN 94 when only the battery is supplying the voltage (alternator/generator turned off or engine not running).

The alert voltage should be chosen to be about half way between these two voltages. For example, in a 14 volt aircraft say the alternator supplied voltage is 13.8 volts as displayed on the SET 9 page with the engine running. The battery supplied voltage with the engine not running is 12.0 volts. An appropriate alert voltage in this case would be 12.9 volts. If an alternator were to fail in flight and the voltage drop to 12.0 volts for at least 15 seconds (or whatever alert delay time was selected), the pilot would be notified of the problem.

NOTE

In order to prevent nuisance messages, this feature should be disabled (Alert Volt OFF) on the SET 9 page on aircraft where the alternator/generator output drops down to a voltage close to the battery voltage during engine idle.

When the maintenance pages are configured as desired, it is necessary to cycle power to the unit in order to leave the maintenance pages and allow normal operation.

2.4.1.5 Maintenance 5 (MNT 5) Page

The MNT 5 page is used to configure the Quicktune™ outputs of the KLN 94. The COMM frequencies stored in the KLN 94 may be sent to up to 4 COMMs that recognize the Quicktune™ labels transmitted over the RS232 bus. The Bendix/King KX155A and KX165A are examples of such a radio.

Similarly, the NAV frequencies stored in the KLN 94 may be sent to up to 4 NAV radios. If a Quicktune™ compatible COMM or NAV is assigned in the KLN94 MNT 5 page (i.e. COMM-2, and NAV-1), then the specific COMMs and NAVs must be configured themselves with the same identifier. For the specific procedure on how to assign an identifier to a KX155A, refer to section 3.1.4.3 of the KX155A Installation Manual.

If a radio number is assigned in the KLN94, a similar operation must be performed in the radio. In other words, if COMM-2 is assigned in the KLN94 as being a valid output, the KX155A (or other Quicktune™-valid receiver) must be configured to accept Quicktune™ frequencies and identified as "COMM2".

If an installation allows more than one Quicktune™ radio (i.e. two or more KX155A), it is not necessarily recommended that both radios should be configured for Quicktune™ operation, but rather consult with the owner and ask for the owner's recommendation. If only one valid Quicktune™ COMM radio is chosen in the MNT 5 page, when the user sets the CRSR over a COMM frequency and presses ENT, the frequency will automatically be placed in the STANDBY slot of the radio. On the other hand, if two or more valid Quicktune™ COMMs are chosen in the MNT 5 page, after pressing ENT on a COMM frequency, the user will be asked to which radio that frequency should be sent. While it increases flexibility, this could be considered a nuisance.

When the installation is complete, the user will be able to choose the default Quicktune™ radios for both COMM and NAV on the SET 14 page. Consult the KLN94 Pilot's Guide for additional information.

2.4.1.6 Maintenance 6 (MNT 6) Page

The MNT 6 page allows the installer to change the nomenclature of the internal annunciators of the KLN94, shown on the right hand side of the KLN94 display.

There are only two combinations allowed. The choices are shown below.

MNT 5 Page Format	Choice 1	Choice 2	Default Settings
Annun:	APR ARM	TERM	APR ARM
	APR ACTV	APR	APR ACTV

If the KLN94 is meant to replace an existing KLN89B and there is already an installation with external annunciators that display “APR ARM” and “APR ACTV”, then the same combination must be chosen in the MNT 6 page in order to have conformity throughout the aircraft. This will also allow the installer to keep the existing external annunciators and switches in place. In a new KLN 94 installation, the external annunciators may not be required. In this case, the user may prefer “choice 2” since it is shorter and more descriptive.

2.4.1.7 Maintenance 7 (MNT 7) Page

The MNT 7 page allows the installer to select between the Standard RS232 Serial Output and the Enhanced RS232 Serial Output. The Enhanced RS232 bus will only work with the Bendix/King Skyforce KMD550 Multifunctional Display, at the time of publication of this manual.

In an installation of the KLN94 with a KMD550 also has additional moving map equipment, the standard RS232 should be chosen, as it will be able to drive a minimal subset of labels in the KMD550 as well as additional equipment.

If you see no published interconnect for your MFD or Moving Map Display, consult the manufacturer for installation information.

2.4.1.8 Maintenance 8 (MNT 8) Page

A Configuring the KLN 94 to operate without roll steering.

1. Select MNT 8 page.
2. Push CRSR button. The cursor will appear over the second line.
3. Select “None” and push CRSR again. The screen should look like:

Configuration Module	DC Roll Steering None
MNT 8	

B. Configuring the KLN 94 to operate with KFC 225 (attitude-based flight control system):

1. Select MNT 8 page.
2. Push CRSR button. The cursor will appear over the second line.
3. Select “Bank Angle” and push CRSR again. The screen should look like:

Configuration Module	DC Roll Steering Bank Angle
MNT 8	

C. Configuring the KLN 94 to operate with KAP 140 (turn-rate-based flight control system):

1. Select MNT 8 page.
2. Push CRSR button. The cursor will appear over the second line.
3. Select “Turn Rate”. “Max Turn Rate” should appear on the fourth line.
4. Turn the outer knob once. The cursor should move to the bottom line.
5. Dial in the autopilot’s maximum turn rate. For KAP 140 as of 7/17/2002, it is 2.7 degrees per second.
6. Push the CRSR agin. The screen should look like:

Configuration Module	DC Roll Steering Turn Rate
MNT 8	Max Turn Rate 2.7 dps

2.4.2 POST INSTALLATION CHECKOUT PROCEDURE

This procedure is divided into two major sections. The first section deals with “Stand Alone” installations in which none of the signal Input/Output capability of the unit is utilized, (except for the RF input signal from the antenna). In this type of installation the only connections to the KLN 94 are the cable from the GPS antenna, the aircraft power and ground leads, and the lighting bus wires.

NOTE

All output data is read from the unit front panel display and all input to the unit is via the front panel controls.

The second part of this procedure deals with an installation in which some or all of the electrical signal I/O have been utilized. This second section is divided in such a way that each input or output signal is treated separately, and hence only those subsections that apply to a given installation will be conducted.

It is assumed that the operator's manual for the various units connected to the KLN 94 (as well as the manual for the KLN 94 itself), are available or that the installer is familiar with operating the units.

2.4.3 INSTALLATION CHECK OUT

Before inserting the unit into the mounting rack, verify that at the rear connector of the mounting rack, aircraft power is present on P942 pin 19, and that there is a ground on P941 pin 14 and P942 pin 20. In installations using 28 V lighting, lighting bus voltage should be present between P941 pins 24 and 14. In installations using 14 V lighting, lighting bus voltage should be present between P941 pins 25 and 14. Verify that there are no voltages or grounds present on any other pins of P941 and P942.

A. Verify that aircraft power is OFF or the unit circuit breaker is pulled. Making sure that the power On/Off switch, located on the front panel of the KLN 94 is rotated the "off" position (power off), plug the unit into the mounting rack and verify that the panel lighting works properly.

B. Energize the unit by rotating the power control switch to the "on" position.

C. Manipulate the controls as necessary to display the Set 1 Page on the right half of the screen. On the Set 1 Page, enter the airport name or the present position (latitude and longitude) for the installation location accurate to within 60 nautical miles. Display the Set 2 Page. Verify that the date and time are correct to within 10 minutes and update if necessary.

D. At this point the aircraft will have to be moved to a location known to have reasonable GPS signal coverage. This implies an outside location away from tall structures that could mask low elevation satellites. (To speed up the next test it is helpful to turn unit power off then on again once the system is away from structures).

E. Proceed to the AUX 1 page. The State shown on the display should change to Acquire (ACQ) from INIT and after a period of not more than 5 minutes, (typically two minutes depending upon the satellite coverage), the unit should display Latitude and Longitude values on the Nav 2 Page that are correct for the installation location. If the unit has not been turned on for 6 months, the unit will take up to 20 minutes to calculate a position.

F. Select the AUX 2 page, verify that no asterisks appear next to any satellite with an elevation greater than 25°. Select 121.15 MHz on COMM 1. Transmit on COMM 1 for a period of 20 seconds and verify that no asterisks appear indicating satellites with an elevation of greater than 25°. Repeat for the following frequencies: 118.000, 120.925, 121.175, 121.200, 123.825, 127.100, 130.625, 131.250, 131.275 131.300 and 134.150 MHz. Repeat the above procedure for all VHF COMM's on board the aircraft.

If any of the above tests do not pass (any asterisks appear on satellites with greater than 25° during the above tests), it will be necessary to identify the source of the interference. There are two common sources of interference:

1. The 12th and 13th harmonics of the above mentioned frequencies can be radiated from the VHF COMM at a level strong enough to be a problem to the GPS but still be well low enough to meet TSO/JTSO requirements for the VHF COMM.

If the interference is from the radiating VHF COMM, an optional notch filter (i.e. the KA 198 P/N 071-01565-0000 or TED Mfg 4-70-54) will need to be installed. The recommended location for the inline filter should be as close to the VHF RT as practical.

NOTE

The conditions and tests performed on this article are minimum performance standards. It is the responsibility of those desiring to install this article either on or within a specific type or class of aircraft to determine that the aircraft installation conditions are within these performance standards. The article may be installed only if further evaluation by the applicant documents an acceptable installation and is approved by the Administrator.

2. The other possibility is re-radiation from an ELT. The radiated RF from the VHF COMM can excite the output tank circuit of the ELT and cause it to oscillate and radiate RF strong enough to interfere with the GPS. If disconnecting the ELT antenna eliminates the GPS interference, the manufacturer of the ELT should be contacted for a recommended solution.

G. Select the AUX 14 page and verify that the first line of that page on the unit display screen reads as follows:

SW REVISION 0X0X

(where 0X0X is the last four digits of the KLN 94 Application Software 206- number)

An entry must be made in the aircraft log book upon installation of the KLN 94, indicating the applicable software revision level. The recommended log book wording is as follows:

KLN 94 Application Software is at SW REVISION 0X0X on DD MMM YYYY.

(where 0X0X represents the last four digits of the KLN 94 Application Software 206- number and DD MMM YYY represents the Day, Month and Year of the installation)

2.4.4 INTEGRATED INSTALLATION CHECK OUT

The following paragraphs define checkout procedures for all possible Input/Output signals that can be connected to the KLN94. It should be clearly determined which of the signals are intended to be used in any given installation and then only the paragraphs pertaining to those signals should be performed.

2.4.4.1 All Installations

Perform all steps defined in [Paragraph 2.4.3](#) and leave the system energized with a valid GPS signal being received.

2.4.4.2 CDI/HSI Interface

Cycle the power on the KLN94, which will cause the self-test page to be displayed. Verify that the CDI needle, after it has settled, is indicating half scale right deflection.

Verify that the TO/FROM flag is indicating FROM. Verify that the nav flag is pulled from view. Verify that the selected course from the CDI/HSI is interfaced properly to the KLN 94 in the OBS Mode. The OBS value on the third line of the self-test page should match the selected course on the CDS/HSI and be with satellite coverage or in take-home mode.

You must create an active waypoint on the Flightplan 0 page to check the following function. The OBS/LEG selection is controlled through the OBS button located on the front panel of the KLN 94. Pressing this button toggles between DTK and OBS with the normal position being DTK. During OBS mode, the DTK indication (located left of the vertical page divider) will change to a three digit course value.

Verify that the selected course value agrees with the value displayed on the HSI Course Pointer. Change the selected course value on the HSI or CDI using the OBS knob. Verify that the selected course value displayed on the KLN94 tracks the new value selected. In the OBS mode with the GPS displayed on the CDI/HSI, the resolver is disconnected from the NAV converter. Verify that the KNS 80 or 81 groundspeed is still functional and the Radial display for the KX 165 or KNS 81 is still functional. These units must have jumpers or resistors across them when the resolver is removed.

In the OBS mode with the GPS not displayed on the CDI/HSI, the resolver is reconnected to the NAV converter. Verify that change in the OBS resolver will not affect the selected OBS on the KLN 94.

2.4.4.3 Gray Code Altitude Inputs

With gray code altitude being supplied by a compatible encoding altimeter, verify that the proper altitude is indicated on the ALT page (provided no other altitude sources are active and that proper baro setting has been entered).

Verify that there is no interference between the KLN 94, transponder, and any other loads on the encoding altimeter output. Remove power from each of the loads on the encoder to verify that the remaining equipment still performs properly. If interference exists, one or more of the units are not diode isolated and isolation diodes will need to be added to the aircraft wiring.

2.4.4.4 RMI Interface

Cycle power on the KLN 94 which will cause the self test page to be displayed. Verify that the RMI indicates 130°.

2.4.4.5 ELT Interface

The following test must be conducted within five minutes after the hour with ELT transmissions limited to 3 (Three) sweeps. A sweep occurs each time there is a voice transmission. Verify that the present position is displayed on the KLN 94 Nav 2 page. Activate the Comm Receiver and tune it to 121.5 MHz. Switch the ELT cockpit toggle switch to TEST. The ELT light should flash and the "sweeping" sound of the ELT should be heard on the Comm Receiver.

Within 1 (one) minute, a voice transmission should be heard which contains the present position displayed on the KLN94 Nav 2 page. Switch the toggle switch to AUTO and push the reset button until it stops flashing.

2.4.4.6 Moving Map Interface

If the KLN 94 is interfaced to a moving map display, verify operation by moving the aircraft out to an open location to acquire a satellite position. Enter an active flightplan or active waypoint to develop a presentation on the map.

Some moving maps require 2 kts of ground speed to display, as the sense track angle is used instead of the heading. The KLN 94 does not output track angles when the groundspeed is below 2 kts.

2.4.4.7 External Annunciators

Recycle the power on the KLN 94 which will cause the Self Test Page to be displayed. Verify that all external annunciators are energized. Cycle the KLN 94 display past all initialization pages. Verify all external annunciators are extinguished. If the message light comes on, view the Message Page to verify that there is a message. If any other annunciator remains lighted, review the status of the KLN94 to determine if the lighted annunciator is justified.

NOTE

Annunciators should be checked one at a time in order to verify that the correct one lights.

2.4.4.8 Quicktune™ Interface

If the KLN 94 is interfaced to a KX 155A / KX 165A for Quicktune™ operation, the following test must be performed to verify the installation. Turn on the KLN 94 and display the APT5 page, where airport frequencies are displayed. choose any airport with at least one frequency. Press the CRSR button, move the cursor on any frequency and press the ENT button. Verify that the selected frequency now appears in the COMM Standby Frequency of the KX155A / KX165A. To verify the NAV part of the operation, display the VOR1 page. Press the CRSR button, move the cursor on the VOR frequency and press the ENT button. Verify that the selected frequency now appears in the NAV Standby Frequency of the KX 155A / KX 165A.

2.4.4.9 Dataloader

The database cartridge may be updated with a new navigation database using a laptop computer. The laptop computer must be IBM compatible and have an available COM port (1, 2, 3, or 4).

Internet Update

A new navigation database can be obtained via the Internet at the following address:
<http://www.gpsdatabase.com>

Store the new database on the hard drive of the PC. Then connect the laptop via the PC loader kit PN 050-03612-0000 (refer to [Figure 2-26](#)). Turn on the KLN 94 to the SET 3 page. Then run the program NETLOAD.EXE and follow the appropriate instructions.

Diskette Update

Connect the laptop via the PC loader kit PN 050-03612-0000 (ref [figure 2-26](#)). Turn on the KLN 94 to the SET 3 page. Insert the 3.5" Database diskette into the PC. Cycle the power of the PC and follow the menu driven instructions. (A small number of PC's may exhibit problems during the load because a few select BIOS services are incompatible with the Honeywell diskettes. If there is uncertainty relating to this, contact Honeywell Product Services at (913) 782-0600, or Navigation Services at 1-800-247-0230 or (913) 712-3145.)

NOTE

The KLN 94 database may be updated using a PC with the KLN 94 mounted in an aircraft (refer to [Figure 2-18](#)).

Cartography databases are only updateable via card exchange. Update frequency has not yet been established but will most likely be annually.

2.4.4.10 ALT ALERT, ALT ALERT AUDIO

Upon approval of the self-test page, five (5) beeps will be issued on the audio output and five (5) sonalert bursts will be produced by the ALT ALERT output, if ALT ALERT has been configured "Enable".

2.4.4.11 Heading Interface

Heading information may be interfaced to the KLN 94 by RS 232 to aid in the calculation of wind vectors and for heading orientation of the NAV 4 or moving map. RS 232 heading information may be provided from an analog to RS 232 converter, such as the Shadin fuel/air data device, through the RS 232 input.

Display the NAV 4 page and select the HDG orientation to test the heading function. If a valid heading source is available, HDG orientation will be selectable. Turn the cursor on the Nav 4 page to display the heading value when the HDG orientation is selected.

2.4.4.12 Flight Control Roll Steering Ground Test

NOTE

This ground test assumes that a KFC 225 Flight Control System is installed.
Ground Test is not available for other Flight Control Systems

Ensure That:

All Gyros used by the Flight Control System need to be spun up to speed and the aircraft needs to be level in the roll axis.

The Attitude Gyro is fully erected and stabilized.

The Flight Control System has conducted and completed a successful pre-flight test.

The GPS is the selected sensor on the primary NAV indicator. The primary NAV indicator shows the signals that the autopilot uses.

Turn the KLN 94 on to initiate its self-test sequence. While the KLN 94 performs its display test, be ready to engage NAV mode on the autopilot, but do not engage the NAV mode yet.

When the NAV flag on the CDI/HSI moves out of view, **immediately** press the NAV button on the KFC 225 computer to engage NAV coupled mode. If unsuccessful, the autopilot will only NAV ARM and not show NAV coupled. If this happens, the KLN 94 must be turned OFF, then turned ON again before the next attempt is made to engage the NAV coupled mode.

When the autopilot is in NAV coupled mode, then:

Turn OFF the KLN 94 cursor by pushing the CRSR button.

Push the KLN 94 PROC button.

Push the KLN 94 OBS button.

Push the KLN 94 PROC button.

Push the KLN 94 OBS button.

The KLN 94 should be outputting a signal equivalent to a 10 degree right bank. This should be evident by the command bars indicating an approximate 10 degree right bank.

Push the KLN 94 CRSR button. The command bars should return to the wings-level state.

2.4.4.13 Aircraft Logbook Entry

Select the AUX 14 page and verify that the first line of that page on the unit display screen reads:

SW REVISION 0X0X

(where 0X0X is the last four digits of the KLN 94 Application Software 206- number)

An entry must be made in the aircraft log book upon installation of the KLN 94, indicating the applicable software revision level. The recommended log book wording is as follows:

KLN-94 Application Software is at SW REVISION 0X0X on DD MMM YYYY.

(where XXXX represents the last four digits of the KLN 94 Application Software 206- number and DD MMM YYY represents the Day, Month and Year of the installation)

2.5 ERROR CODES

The KLN 94 provides numeric error codes and text messages for certain failures. The following table may assist in identifying the root cause of these problems.

GPS Rec. Error Codes	Definition	Suggested Action
RCVR Hardware Error: XXXX:	This message appears when the KLN 94 fails a specific internal test for the GPS receiver. The possible error codes are described below:	
RCVR Hardware Error: 0002	ROM Failure: The ROM memory has failed self-test.	Bad ROM. Return for service.
RCVR Hardware Error: 0004	RAM Failure: The RAM memory has failed self-test.	Bad RAM. Return for service.
RCVR Hardware Error: 0008	Nonvolatile Memory Failure: The battery-backed RAM has failed a checksum test. Non-volatile memory will be cleared.	<p>It could be one of the following, in the order of probability:</p> <ol style="list-style-type: none"> 1. The battery-backup power to the GPS Receiver was lost. This could be due to either a dead internal battery or a bad connection on the cable to the receiver. 2. The RAM memory is bad.
RCVR Hardware Error: 0010	RF Failure: This means the receiver is not sensing a proper RF signal from the satellites/antenna.	<p>It could be one of the following, in the order of probability:</p> <ol style="list-style-type: none"> 1. Coax open or shorted. Confirm the 5 volts at the antenna end. 2. Bad antenna. Substitute the antenna or inject a signal at the coax. 3. Bad Receiver Module in GPS. Substitute the GPS unit or inject signal at the input.
RCVR Hardware Error: 0080	ASIC Failure: The GPS Correlator ASIC fails self-test.	<p>It could be one of the following, in the order of probability:</p> <ol style="list-style-type: none"> 1. The flex cable between the Receiver and Main Board may have come out of the socket in the GPS. 2. Bad ASIC on receiver module in GPS. Substitute the GPS unit.

GPS Rec. Error Codes	Definition	Suggested Action
RCVR Hardware Error: 0100	BBP Timeout: The 1 mS baseband processing timer has failed self-test.	<p>It could be one of the following, in the order of probability:</p> <ol style="list-style-type: none"> 1. The 5 volt supply to the antenna could be shorted out in the coax. This disables the oscillator in the GPS. 2. The flex cable between the Receiver and Main Board may have come out of the socket in the GPS. 3. Bad TCXO or ASIC on receiver module in GPS. Substitute the GPS unit.
RCVR Hardware Error: 0400	RS 232 Receiver Failure: The GPS Receiver did not receive any initialization data from the host computer on the RS 232 port.	<p>It could be one of the following, in the order of probability:</p> <ol style="list-style-type: none"> 1. The flex cable between the Receiver and Main Board may have come out of the socket in the GPS. 2. Bad 32KHz crystal, UART, or processor on Receiver Module in GPS. Substitute the GPS unit.
RCVR Hardware Error: 0800	EEPROM Failure: The EEPROM memory has failed its checksum.	Bad EEPROM. Return for service.
RCVR Hardware Error: 1000	RS 232 Channel 2 Failure: The second RS 232 UART on the receiver has failed the loop-back test. This self-test can only be enabled during test mode on the receiver and should not be seen in normal operation.	<p>It could be one of the following, in the order of probability:</p> <ol style="list-style-type: none"> 1. The receiver was put in test mode without looping back the two serial ports. 2. Bad ASIC or Microprocessor on the receiver.
RCVR Hardware Error: 2000	BBP Underflow: The baseband processing loop detected an error in the 1mS processing loop.	<p>It could be one of the following, in the order of probability:</p> <ol style="list-style-type: none"> 1. The flex cable between the Receiver Board and the Main Board mat have come out of the socket in the GPS. 2. Bad TCXO, MMIC, or ASIC on the Receiver Board.
RCVR Hardware Error: 8000	BBP Overflow: The baseband processing loop detected an error in the 1mS processing loop.	<p>It could be one of the following, in the order of probability:</p> <ol style="list-style-type: none"> 1. The flex cable between the Receiver Board and the Main Board mat have come out of the socket in the GPS. 2. Bad TCXO, MMIC, or ASIC on the Receiver Board.

TABLE 2-1 GPS RECEIVER ERROR CODES

GPS Page Messages	Definition	Suggested Action
Altitude Fail	<p>Indicates a missing or erroneous altitude.</p> <p>The altitude input on the gray code input from the encoder is wrong.</p> <p>The GPS is configured for IFR and there is no altitude source available.</p>	<p>The altitude from the encoder may be in error due to a miswire, or the absence of isolation diodes between the encoder and the transponder.</p> <p>If the GPS is configured for IFR, it must have a valid altitude. Verify the presence of altitude on the Self-Test or Altitude Pages (press the ALT button).</p>
NAV Superflag Failure	<p>Indicates an internal test of the NAV Superflag output has failed.</p>	<p>When the flag is supposed to be valid, it should reach a minimum voltage. Usually a failure is due to overloading of the output. The output can be tested when the Self-Test Page is displayed.</p>
<p>RAIM position error</p> <p>Cross check position</p>	<p>RAIM is a method of calculating integrity of the GPS position. It calculates the position multiple times using different sets of satellites and compares the answers. If they have excessive differences, the message appears.</p>	<p>It could be one of the following, in the order of probability:</p> <ol style="list-style-type: none"> 1. This probably is a GPS failure. Cross check your position by other means of navigation. Return for service. 2. The GPS has detected a problem with one of the satellites and cannot be assured to be within IFR limits.
No RS 232 Data	<p>There is no RS 232 data at the RS 232 input port.</p>	<p>The Air Data/Fuel Flow source is not outputting RS 232 data to the GPS. If no source of RS 232 is interfaced, the receiver input must be jumpered back to the RS 232 output.</p>
<p>RAIM not available</p> <p>Cross check position</p>	<p>This means there are not enough satellites available to compute integrity (RAIM).</p> <ol style="list-style-type: none"> 1. The satellites are blocked from view by obstructions. 2. The satellites are too low on the horizon for use or too high for adequate geometry. 3. There is a loss of sensitivity in the antenna, the coax or receiver module. 	<p>The aircraft should be in an open area with good visibility and the SNR (Signal to Noise Ratio) on the AUX 2 page should be:</p> <p>A KLN 94 will usually have 6-8 satellites shown and the majority of their SNR values will be 7 to 9. SNR values of 3 and below are unusable, 4 is marginal and 5-9 are considered good. If the SNR values are low, it could be one of the following, in order of probability:</p> <ol style="list-style-type: none"> 1. Check the antenna coax and connection for problems. 2. Verify that 5 volts is present at the antenna end of the coax. 3. Substitute the receiver to check for sensitivity. 4. Substitute the antenna to check for sensitivity.

GPS Page Messages	Definition	Suggested Action
<p>RAIM not available</p> <p>Cross check position</p>	<p>This means there are not enough satellites available to compute integrity (RAIM).</p> <ol style="list-style-type: none"> 1. The satellites are blocked from view by obstructions. 2. The satellites are too low on the horizon for use or too high for adequate geometry. 3. There is a loss of sensitivity in the antenna, the coax or receiver module. 	<p>The aircraft should be in an open area with good visibility and the SNR (Signal to Noise Ratio) on the AUX 2 page should be:</p> <p>A KLN 94 will usually have 6-8 satellites shown and the majority of their SNR values will be 7 to 9. SNR values of 3 and below are unusable, 4 is marginal and 5-9 are considered good.</p> <p>If the SNR values are low, it could be one of the following, in order of probability:</p> <ol style="list-style-type: none"> 1. Check the antenna coax and connection for problems. 2. Verify that 5 volts is present at the antenna end of the coax. 3. Substitute the receiver to check for sensitivity. 4. Substitute the antenna to check for sensitivity.
<p>RAIM not available</p> <p>Approach mode inhibited</p> <p>Predict RAIM on AUX 3</p>	<p>This is a calculated prediction of RAIM availability. The message appears when integrity monitoring (RAIM) is predicted to not be available at either the FAF or MAP.</p> <p>The GPS will not allow the unit to go into APR ACTV mode until conditions improve.</p>	<p>This is a feature, not a system failure.</p> <p>Turn to the AUX 3 page to perform a RAIM prediction. It will give you an indication of how long it will be until RAIM is available.</p> <p>This prediction can also be performed prior to departure to insure RAIM at your arrival.</p>

TABLE 2-2 GPS PAGE MESSAGES

GPS System Error Codes	Definition	Suggested Action
KLN 94 System Error Code XXXX	System Error Codes reflect an error detected deep in the system. Some of the numeric codes will be described below:	Most of the System Errors require the attention of a service center. Please note as many details as possible when the failure occurred and identify if it is repeatable.
001	Initialization Failure	
003	Failed Powerup Self-Test	
006	Exception Interrupt Detected. The processor received an undesirable interrupt request.	Cycle the power and see if the error is repeatable. If repeatable, take the unit to a Service Center.
017	Run Time Database Checksum Failed. An error was detected on the internal NAV database chip.	Bad internal NAV database chip. Return for service.
025	ADC reference failed. The reference voltage to the Analog to Digital Converter is not at a proper level.	
101	Unit Not Responding	
102	Bad Application Program	
103	Invalid or Missing Database Card	

TABLE 2-3 GPS SYSTEM ERROR CODES

NOTE

If any error code appears other than the ones listed above, contact Honeywell Product Support at (913) 782-0600.

SECTION III OPERATION

3.1 GENERAL INFORMATION

For an explanation of the operating controls of the KLN 94 GPS RNAV refer to the KLN 94 Pilot's Guide (P/N 006-18207-0000) or the aircraft's flight manual supplement.

THIS PAGE IS RESERVED.

APPENDIX A
RS-232 FORMAT DEFINITIONS

1.0 GENERAL RS-232 IN

The RS-232 interface will have the following characteristics:

BYTE FORMAT
Electrical per EIA RS 232C
9600 baud, 8 bits, 1 stop bit, no parity
MARK is a logical 1 (one) and SPACE is a logical 0 (zero)
START bit begins as MARK, goes to SPACE

The receiving order of data bits within each data byte shall be:

START bit
Data bit 0 (LSB)
Data bit 1
Data bit 2
Data bit 3
Data bit 4
Data bit 5
Data bit 6
Data bit 7 (MSB)
STOP bit

Fuel/air data input protocol

Fuel/air data sent by the Airdata computer shall be received in a block having one of the following formats:

FORMAT A (13 BYTE ASCII STRING)	
BYTE	DESCRIPTION / FORMAT
1	STX (ASCII code 02H)
2	Unit of Measure G = .1 gallon I = .1 imperial gallon L = 1 liter K = 1 kilogram B = 1 pound
3-6	Fuel Remaining ASCII-coded decimal format, LSB first Example: A fuel remaining value of 432 would be sent as "2340" (32H, 33H, 34H, 30H).
7	Fuel Remaining Checksum: Break each decimal value into BCD representation. Using BCD arithmetic, sum the 4 BCD values and convert the lower-order BCD digit to an ASCII coded numeric digit. Example: The checksum for a value of 432 would be "9" (39H).
8-11	Fuel Flow Rate (units / hours) ASCII-coded decimal format as used for Fuel Remaining.
12	Fuel Flow Rate Checksum Sum of fuel flow rate bytes computed as described for Fuel Remaining checksum.
13	EXT (ASCII code 03H) NOTE: 1. Fuel remaining and fuel flow rate information shall be for the complete aircraft. 2. This 13 byte record shall be transmitted every 1.6 seconds ± 0.16 seconds.

FORMAT B (52 BYTE ASCII STRING)	
BYTE	DESCRIPTION
1	STX (ASCII code 02H)
2	Unit of Measure G = .1 gallon I = .1 imperial gallon L = 1 liter K = 1 kilogram B = 1 pound
3-8	Total Fuel Remaining ASCII-coded decimal format (least significant digit is tenths), LSB first Example: A fuel remaining value of 543.2 would be sent as "2.3450" (32H, 2EH, 33H, 34H, 35H, 30H).
9	Total Fuel Remaining Checksum Break each decimal value into BCD representation. Using BCD arithmetic, sum the 4 BCD values and convert the lower-order BCD digit to an ASCII coded numeric digit. Example: The checksum for a value of 543.2 would be "4" (34H).
10-15	Total Fuel Flow Rate ASCII-coded decimal format as for Total Fuel Remaining.
16	Total Fuel Flow Rate Checksum Sum of fuel flow bytes computed as for Total Fuel Remaining.
17-22	Engine One Fuel Flow Rate ASCII-coded decimal format as for Total Fuel Remaining
23	Engine One Fuel Flow Rate Checksum Sum of Left Engine Fuel Flow Rate bytes computed as for Total Fuel Remaining
24-29	Engine Two Fuel Flow Rate ASCII-coded decimal format as for Total Fuel Remaining.

FORMAT B (52 BYTE ASCII STRING) - con't	
BYTE	DESCRIPTION
30	Engine Two Fuel Flow Rate Checksum Sum of Right Engine Fuel Flow Rate bytes computed as for Total Fuel Remaining
31-36	Total Fuel Used ASCII-coded decimal format as for Total Fuel Remaining
37	Total Fuel Used Checksum Sum of Total Fuel Used bytes computed as for Total Fuel Remaining
38-43	Engine One Fuel Used ASCII-coded decimal format as for Total Fuel Remaining
44	Engine One Fuel Used Checksum Sum of Left Engine Fuel Flow Rate bytes computed as for Total Fuel Remaining
45-50	Engine Two Fuel Used ASCII-coded decimal format as used for Total Fuel Remaining
51	Engine Two Fuel Used Checksum Sum of Left Engine Fuel Flow Rate bytes computed as for Total Fuel Remaining
52	ETX (ASCII code 03H) NOTE: 1. In the case of single engine aircraft, all Engine One and Engine Two data (including checksums) shall be asterisks (ASCII code 2AH). 2. This 52 byte record shall be transmitted every 1.6 seconds \pm 0.16 seconds.

FORMAT C (108 BYTE ASCII STRING)	
BYTE	DESCRIPTION / FORMAT
1-51	Same as Format B described above except that in the Units of Measure field, "l = Imperial Gallons" is undefined.
52-54	Indicated Airspeed (IAS, knots) ASCII-coded decimal format (least significant digit is units), LSB first. Example: An IAS of 298 knots would be sent as "892" (38H, 39H, 32H).
55	Indicated Airspeed Checksum Break each decimal value into BCD representation. Using BCD arithmetic, sum the 3 BCD values and convert the lower-order BCD digit to an ASCII coded numeric digit.
56-58	True Airspeed (TAS, knots) ASCII-coded decimal format as for IAS
59	True Airspeed Checksum Sum for TAS bytes computed for IAS.
60-62	MACH (airspeed/speed of sound) ASCII-coded decimal format with an implicit leading decimal point (least significant digit is thousands). Example: A MACH value of .492 would be sent as "294" (32H, 39H, 34H).
63	MACH Checksum Sum for MACH bytes computed as for IAS.
64-69	Pressure Altitude (PALT, feet) ASCII-coded decimal format with a sign character. Example: A PALT of 34500 feet would be sent as "00543+" (30H, 30H, 35H, 34H, 33H, 2BH).
70	Pressure Altitude Checksum Sum for PALT bytes, excluding the sign character. Example: The sum for -850 feet would be "3" (33H).

FORMAT C (108 BYTE ASCII STRING) - con't	
BYTE	DESCRIPTION / FORMAT
71-76	Density Altitude (DALT, feet) ASCII-coded decimal format with a sign character, as for PALT.
77	Density Altitude Checksum Sum for DALT bytes, excluding the sign character, as for PALT.
78-80	Total Air Temperature (×C) ASCII-coded decimal format with a sign character Example: An OAT of 25×C would be sent as "52+".
81	Total Air Temperature Checksum Sum for total air temperature bytes, excluding the sign byte, as for PALT.
82-84	Wind Direction (degrees from true North) ASCII-coded decimal format Example: 122 degrees would be sent as "22" (32H, 32H, 31H).
85	Wind Direction Checksum Sum for wind direction bytes, as for IAS
86-88	Wind Speed (knots) ASCII-coded decimal format, as for IAS
89	Wind Speed Checksum Sum for wind speed bytes, as for IAS
90-92	Drift (degrees) ASCII-coded decimal format with a direction character Example: 7 right would be sent as "70R", 14 left would be sent as "41L".

FORMAT C (108 BYTE ASCII STRING) - con't	
BYTE	DESCRIPTION / FORMAT
93	Drift Checksum Sum for drift bytes, excluding the direction character Example: The sum for "41L" would be "5" (35H).
94-98	Rate of change of PALT (feet/minute) ASCII -coded decimal format with a sign character Example: A PALT rate of change of -210 ft/min (descent), would be "012-" (30H, 31H, 32H, 30H, 2DH).
99	Rate of change of PALT checksum Sum for PALT rate of change bytes, excluding the sign character, as for PALT.
100-102	Magnetic Heading (degrees from magnetic North) ASCII-coded decimal format, as for wind direction
103	Magnetic Heading Checksum Sum for magnetic heading bytes, as for IAS
104-106	Static Air Temperature (×C) ASCII-coded decimal format with a sign character Example: A static air temperature of -2×C would be sent as "20-".
107	Static Air Temperature Checksum Sum for static air temperature bytes, excluding the sign character, as for PALT.
108	ETX (ASCII code 03H)

FORMAT D (121 BYTE ASCII STRING)	
BYTE	DESCRIPTION / FORMAT
1-107	Same as Format C described above except that bytes 3 through 9 shall be filled with asterisks if total fuel remaining is not available and consequently must be entered through the KLN 94.
108-112	Barometric Setting (inches HG) ASCII-coded decimal format (least significant digit is hundredth of inches), LSB first. Example: A barometric setting of 29.83 inches HG would be sent as "38.92" (33H, 38H, 2EH, 39H, 32H).
113	Barometric Setting Checksum Break each decimal value into BCD representation. Using BCD arithmetic, sum the 4 BCD values and convert the lower-order BCD digit to an ASCII-coded numeric digit. Example: The checksum for a value of 29.83 would be "2" (32H).
114-119	Baro-corrected Altitude (feet) ASCII-coded decimal format with a sign character Example: A baro-corrected altitude of +11000 feet would be sent as "00011+" (30H, 30H, 30H, 31H, 31H, 2BH).
120	Baro-corrected Altitude Checksum Sum for baro-corrected altitude bytes computed, excluding sign character, as for pressure altitude.
121	EXT (ASCII code 03H)

FUEL FLOW & AIR DATA CONFIGURATION

The fuel flow and air data equipment configuration can be setup on MNT 1 page.

1. Fuel flow equipment installed and Air data equipment not installed:

Any the above formats may be received. If format C or D is received, the airdata portions are ignored, the fuel data portions are used, and no error message is given.

2. Fuel flow equipment not installed and Air data equipment installed:

If format C or D is received, fuel data portions are ignored, the airdata portions are used and no error message is given. If format A or B is received, the "GEN RS-232 In Data Error" message is displayed.

3. Both fuel flow equipment and air data equipment not installed:

If no data is received for this setup, the "No GEN RS-232 In Data" message will be displayed.

Fuel/Air Data Timing Requirement

A grace period of 2.4 seconds, in addition to the 1.6 second transmission interval, shall be given to every fuel/air data transmission. The unit invalidates all local copies if fuel/air data is not received for 4.0 seconds \pm .40 seconds.

2.0 GENERAL RS232 OUT

Functional Description

BYTE FORMAT
Electrical per EIA RS 232C
9600 baud, 8 bits, 1 stop bit, no parity
MARK is a logical 1 (one) and SPACE is a logical 0 (zero)
START bit begins as MARK, goes to SPACE

The order of transmission within each data byte shall be:

START bit
Data bit 0 (LSB)
Data bit 1
Data bit 2
Data bit 3
Data bit 4
Data bit 5
Data bit 6
Data bit 7 (MSB)
STOP bit

Data Protocol

Data shall be sent in blocks having the following format:

<STX><id><dddd><it><id><dddd><it>...<id><dddd><it><ETX>	
<STX>	ASCII start of text character
<id>	item designator
<dddd>	item data
<it>	item terminator
<CR>	ASCII carriage return character
<STX>	ASCII end of text character
<STX>	ASCII end of text character
<id>	item designator
<dddd>	item data
<it>	item terminator
<CR>	ASCII carriage return character
<STX>	ASCII end of text character

Any data which is invalid or exceeds the data format will be filled with dashes.

RS232 OUTPUT DATA ITEM DEFINITIONS

There are two RS232 output data item definitions, as represented in the following tables. The first table shows the Standard definitions, as selected on the MNT7 page (see [paragraph 2.4.1.7](#) in this manual).

STANDARD RS232			
Item Designator	Data Format	Data Field Width	Description
A	s dd mmhh	9	present latitude; dash if position flag is set. s=sign: N for North, S for South dd=degrees mm=minutes hh=hundreths of minutes

STANDARD RS232			
Item Designator	Data Format	Data Field Width	Description
B	s ddd mmhh	10	present longitude; dash if position flag is set s=sign: E for East, W for West ddd=degrees mm=minutes hh=hundreths of minutes
C	ddd	3	magnetic track, degrees; dash if GS is set
D	ddd	3	groundspeed, knots; dash if position flag is set
E	dddd	5	10 x distance to active waypoint, nm; dash if Nav Flag is set
G	sdddd	5	crosstrack error; dash if Nav Flag is set s=sign: R for aircraft position right of course, L for aircraft position left of course. dddd=1000 x crosstrack error, nm
I (INDIA)	dddd	4	10 x magnetic desired track, degrees (use selected course in OBS mode); dash if Nav Flag is set.
K	dddd	5	active waypoint identifier
L	dddd	4	10 x magnetic bearing to active waypoint, degrees (use radial from active waypoint 180 in OBS mode); dash if Position Flag is set.
Q	sddd	4	magnetic variation; dash if Position Flag is set s=sign: E for East, W for West add=10 magnetic variation, degrees
T	---A----		warnings; 4th character is "A" if estimated position error exceeds 3.8nm, otherwise "-"
I (lima)	dddddd	6	10 x distance to destination, nm; dash if Nav Flag is set
u	free fromat		for development testing only
w	ddsiiiiiiLLLLmm	17	flight plan waypoint data; this item is sent for each waypoint in the active flight plan dd=waypoint number (01-25) s=sequence number bits: 76543210 xlannnn x=unused, l=1 is last waypoint, a=1 if active wpt nnnnn=sequential number, unassigned binary iiii=identifier

STANDARD RS232			
Item Designator	Data Format	Data Field Width	Description
a	Snnnnn	17	baro-corrected external altitude input S=sign: + or - nnnnn=altitude, feet (to nearest foot); dash if not valid
j	hh:mm:ss	8	UTC time of data
t	abcdefghij	10	GPS discrettes a=W for waypoint alert; T for turn; else dashed b=N for new message; P for persistent message; else dashed c=E for enroute; T for terminal; R for approach arm; or A for approach active d=L for leg; D for Direct-to; O for OBS; T for OBS Æ LEG transition e=T for TO; F for FROM; else dashed fghij= reserved for future use; currently dashed

ENHANCED RS232			
Item Designator	Data Format	Data Field Width	Description
A	s dd mmhh	9	present latitude; dash if position flag is set. s=sign: N for north, S for south dd=degrees mm=minutes hh=hundredths of minutes
B	s ddd mmhh	10	present longitude; dash if position flag is set. s=sign: E for east, W for west ddd=degrees mm=minutes hh=hundredths of minutes
C	ddd	3	magnetic track, degrees; dash if GS<2 kts or position flag is set.
D	ddd	3	groundspeed, knots; dash if position flag is set.
E	dddd	5	10 ÷ distance to active waypoint, nm; dash if nav flag is set.

ENHANCED RS232			
Item Designator	Data Format	Data Field Width	Description
G	sdddd	5	crosstrack error; dash if nav flag is set. s=sign: R for aircraft position right of course, L for aircraft position left of course dddd=100 X crosstrack error, nm
I (upper case INDIA)	dddd	4	10 X magnetic desired track, degrees (use selected course in OBS mode); dash if nav flag is set.
K	dddd	5	active waypoint identifier
L	dddd	4	10 X magnetic bearing to active waypoint, degrees (use radial from active waypoint $\pm 180^\circ$ in OBS mode); dash if position flag is set.
Q	sddd	4	magnetic variation; dash if position flag is set. s=sign: E for east, W for west ddd=10 X magnetic variation, degrees
T	---A----	9	warnings; 4th character is "A" if estimated position error exceeds 3.8 nm, otherwise "-"
a	snnnnn	6	baro-corrected external altitude input s=sign: + or - nnnnn=altitude, feet (to nearest foot); dash if not valid
j	hh:mm:ss	8	UTC time of data hh=hours; mm=minutes; ss=seconds
l	dddddd	6	10 X distance to destination, nm; dash if nav flag is set.
q	ttffff	7	QuickTune™ frequency t = target radio f = frequency data This item is sent once when a COMM or NAV frequency is selected for external QuickTune. It is not sent as part of the normal data stream. This data shall be sent at the first available time slot on the bus. The time delay shall be no greater than one second.

ENHANCED RS232			
Item Designator	Data Format	Data Field Width	Description
q (cont)	ttffff	7	<p><u>Byte 1--System Type:</u> ASCII 0 is undefined ASCII 1 = COM ASCII 2 = NAV ASCII 3 and above are currently undefined</p> <p><u>Byte 2--System Number:</u> ASCII 0 is undefined ASCII 1 = System 1 ASCII 2 = System 2 ASCII 3 = System 3 ASCII 4 = System 4 ASCII 5 and above are currently undefined</p> <p><u>Bytes 3-7—Frequency:</u> This data is equal to (Frequency – 100) * 1000</p> <p>It is assumed that all frequencies are in the 100-199 MHz range, so hundreds of megahertz are omitted.</p>
t	abcdefghij	10	<p>GPS discrettes a=W for waypoint alert; T for turn; else dashed b=N for new message; P for persistent message; else dashed c=E for en route; T for terminal; R for approach arm; or A for approach active d=L for LEG; D for direct-to; O for OBS; T for OBS->LEG transition, V for VTF. e=T for TO; F for FROM; else dashed fghij=reserved for future use; currently dashed</p>
u	free format		for development testing only
w	ddsiiiiIIIIIIImm	17	<p>flight plan waypoint data^{1,2,3}; this item is sent for each waypoint in the active flight plan dd=waypoint number (01 ~ 25)</p> <p>s=discrettes bits: 76543210 xladsgit t=0 leg follows; t=1 arc follows i=1 no-point-symbol in map (for invisible wpt) g=1 gap follows (for visible non-connected wpt)</p>

ENHANCED RS232			
Item Designator	Data Format	Data Field Width	Description
w (cont)	ddsiiiiIIIIIIImm	17	<p>s=1 active segment follows (for other magenta segments) d=0 solid line; d=1 dashed line a=1 active wpt l=1 last waypoint x=unused</p> <p>iiii=identifier (ASCII characters); a value of 7F hex in first byte indicates unknown ident, remaining bytes should be ignored. III=waypoint latitude; packed, unsigned binary values: 76543210 76543210 76543210 sddddddd xxmmmmm xhhhhhhh s=sign: 0 for north, 1 for south ddddddd=degrees x=unused mmmmmm=minutes hhhhhh=hundredths of minutes A value of 7F hex in the first byte indicates that latitude and longitude are unknown, and remaining bytes should be ignored. LLLL=waypoint longitude; packed, unsigned binary values: 76543210 76543210 76543210 76543210 sxxxxxxx dddddddd xxmmmmm xhhhhhhh s= sign: 0=East 1=West, x=unused, d=degrees, m=minutes, h=hundredth mm=magnetic variation at waypoint 76543210 76543210 nnnnnnnn nnnnnnnn nnnnnnnnnnnnnnnn=Magnetic variation at waypoint Two's complement binary in sixteenths of degrees. Easterly variation is positive. A value of 7FH in byte 16 indicates that magnetic variation is not presently available and bytes 16 and 17 should be ignored.</p>

ENHANCED RS232			
Item Designator	Data Format	Data Field Width	Description
x	srr	3	<p>Arc Description</p> <p>s= misc bits: 76543210 xljnnnnn nnnnn=waypoint number –uns bin(01 ~ 25) j=1 ">180°"; j=0 "<180°" l=1 clockwise; l=0 counterclockwise x=unused</p> <p>rr=100 X radius, nm; uns.binary (655.36 max)</p>
z (lower case)	aaaaa	5	<p>Current GPS altitude in feet. If altitude is negative, this label shall format "-aaaa" (Note only four digits).</p>

THIS PAGE IS RESERVED.

APPENDIX B

Includes the following:

KLN 94 SUPPLEMENTAL PROCEDURES MANUAL

KLN 94 FLIGHT MANUAL SUPPLEMENT

FLIGHT MANUAL SUPPLEMENT PROCEDURE

For the installation of the KLN 94 GPS to be FAA approved for enroute and approach IFR operation, it is necessary for the installer to create a flight manual supplement that is unique for the installation and to submit that supplement to the FAA for approval.

Following, you will find a copy of the flight manual supplement created by Honeywell International, Inc. for the initial STC installation of the KLN 94 in Mooney model M20C. Use this supplement as a guide in creating the supplement for your installation (do not copy the 006- part number in the footer). If your installation is interfaced to the same equipment (i.e. switches, annunciators, RMI, autopilot, etc.) as the initial installation, copy the guide supplement in its entirety, changing only the installers name and address, aircraft make and model, approval authorization and section titles/numbers to suit your circumstances as detailed below. More likely, if your installation is not identical to the initial installation, it will be necessary for you to determine the differences and alter your supplement accordingly. Elements of the supplement which may need to be altered for your installation are as follows:

1. FORMAT

The format of the finished supplement should match, as closely as possible, the format of the aircraft's flight manual and/or pilot's operating handbook. Sizing of your manual to match the aircraft's flight manual is most easily accomplished by creating it first as an 8 1/2" X 11" (standard typewriter size paper) document and then reducing that on a reducing copier to the size required before submitting it to the FAA for approval. (Most small aircraft have flight manuals of 5 1/2" X 8 1/2" size. This size has a different height/width ratio than the 8 1/2" X 11" size; the width is narrower. The guide supplement is proportioned correctly for reduction to 5 1/2" X 8 1/2" size; copy its proportions if you are planning to reduce your supplement).

The headers and footers of the guide supplement may be rearranged to match the format of your aircraft's flight manual; however, most of the information shown is required on every page. The Honeywell part number should not appear in your supplement, but the footer should include the page number, in the format "PAGE _OF _", and the words "FAA APPROVED" and a blank space for the date of the approval in place of the "ORIGINAL ISSUE" of the guide supplement. The aircraft for which the supplement applies should also be identified by manufacturer and model number as shown on the aircraft's serial data plate, i.e. Beech A36 or Piper PA-46-310P (not marketing name like Bonanza, Malibu, etc.).

Headers must identify the section of the supplement for that page. Additionally, we have found it useful to include identification of the system in the header for ease of pilot reference.

The section numbers and names in the guide supplement are typical of many aircraft; however, you should check the aircraft's flight manual and match those section numbers and names when organizing your supplement.

2. COVER

The cover page for your supplement should essentially be identical to the guide supplement with the following exceptions:

- A. In the header, substitute the installers name and address (whoever is writing the flight manual supplement) in place of the name and address of Honeywell.
- B. Substitute the manufacturer's name and model number (as shown on the serial data plate) for your aircraft in place of the Mooney models listed.
- C. In the second line of text, where the sample supplement states "is installed in accordance with STC SA00244WI-D.", substitute "is installed in accordance with unit Installation Manual 006-_____-_____, Rev.____, and FAA Form 337 dated .". (Insert the part number and revision of the manual you have used).
- D. Remove "CHRIS DURKIN, DAS Coordinator, Honeywell International, Inc." and "DAS4CE" from below the FAA APPROVED line. (Your supplement will be approved by an FAA representative).
- E. Remove the footer on the cover page. (The footer on the guide supplement cover page is for Honeywell internal reference only).

3. TABLE OF CONTENTS

If the section names and numbers of your aircraft's flight manual do not match those of the sample flight manual supplement, you should arrange your Table of Contents and your supplement in accordance with the format of your aircraft's flight manual.

4. BODY OF TEXT

The body of text for all sections other than NORMAL PROCEDURES should be copied in its entirety. The text for the NORMAL PROCEDURES section may vary depending on the equipment interfaced with the KLN 94. Some of the annunciators, switches and/or controls described in paragraph B may differ slightly or may not be included as part of your installation. Should this be the case, you will need to alter the text of this paragraph and its subparagraphs to accurately describe the operation of the KLN 94 as it exists in your installation. Do not include descriptions of annunciators, switches or controls not present in your installation. Make sure that the nomenclature on the items you do use matches the description in your flight manual supplement.

This concludes the procedure for writing a KLN 94 GPS Aircraft Flight Manual Supplement. Reduce the pages as required to match the format of your aircraft's flight manual, and you are ready to submit the new document to your local FAA representative for approval.

THIS PAGE IS RESERVED.

Honeywell
Olathe, Kansas

BENDIX/KING®
KLN 94 SUPPLEMENT

FAA APPROVED
AIRPLANE FLIGHT MANUAL SUPPLEMENT
FOR
BEECH MODELS 95-55, 95-A55, 95-B55,
95-B55A, 95-B55B, 95-C55, 95-C55A, D55,
D55A, E55, E55A
WITH
BENDIX/KING® KLN 94 NAVIGATION SYSTEM

Reg. No. _____

Ser. No. _____

This supplement must be attached to the FAA Approved Airplane Flight Manual when the Bendix/King KLN 94 GPS is installed in accordance with STC SA00909WI-D. The information contained herein supplements or supersedes the basic manual only in those areas listed herein. For limitations, procedures, and performance information not contained in this supplement; consult the basic Airplane Flight Manual.

FAA APPROVED: _____

FOR

CHRIS DURKIN
DAS Coordinator
Honeywell International Inc.
DAS-500863-CE

DATE: _____

11-1-2000

FAA APPROVED: ORIGINAL ISSUE

006-00877-0000

LOG OF REVISIONS

REV	PAGE(S)	DESCRIPTION	APPROVAL/DATE
-	All	Original issue.	See Cover.

TABLE OF CONTENTS

<u>Section</u>	<u>Page</u>
I GENERAL	1
II LIMITATIONS	3
III EMERGENCY PROCEDURES.....	6
IV NORMAL PROCEDURES	7
V PERFORMANCE.....	17

SECTION I- GENERAL

The KLN 94 GPS panel mounted unit contains the GPS sensor, the navigation computer, a Color LCD display, and all controls required to operate the unit. It also houses the data base card which plugs directly into the front of the unit.

The data base card is an electronic memory containing information on airports, nav aids, intersections, DPs, STARs, instrument approaches, special use airspace, land data (roads, bodies of water, cities, obstacles, railroad tracks), and other items of value to the pilot.

Every 28 days, Bendix/King receives new aeronautical data base information from Jeppesen Sanderson for the North American data base region. (The land data is updated on a less frequent basis.) This information is processed and downloaded onto the data base cards. Bendix/King makes these data base card updates available to KLN 94 GPS users.

Provided the KLN 94 GPS navigation system is receiving adequate usable signals, it has been demonstrated capable of and has been shown to meet the accuracy specifications of:

VFR/IFR en route oceanic and remote, en route domestic, terminal, and instrument approach (GPS, Loran-C, VOR, VOR-DME, TACAN, NDB, NDB-DME, RNAV) operation within the U.S. National Airspace System, North Atlantic Minimum Navigation Performance Specifications (MNPS) Airspace and latitudes bounded by 74° North and 60° South using the WGS-84 (or NAD 83) coordinate reference datum in accordance with the criteria of AC 20-138, AC 91-49, and AC 120-33. Navigation data is based upon use of only the global positioning system (GPS) operated by the United States.

NOTE: Aircraft using GPS for oceanic IFR operations may use the KLN 94 to replace one of the other approved means of long-range navigation. A single KLN 94 GPS installation may also be used on short oceanic routes which require only one means of long-range navigation.

NOTE: The KLN 94 is qualified for BRNAV (Basic Area Navigation) operation in the European region in accordance with the criteria of AC 90-96. (Reference ICAO Doc 7030 Regional supplementary Procedures, JAA Technical Guidance Leaflet AUJ20X2 and Eurocontrol RNAV Standard Doc 003-93 Area Navigation Equipment Operational Requirements and Functional Requirements (RNAV).)

NOTE: FAA approval of the KLN 94 does not necessarily constitute approval for use in foreign airspace.

SECTION II - LIMITATIONS

- A. The KLN 94 GPS Pilot's Guide, P/N 006-18207-0000, dated September, 2000 (or later applicable revision) must be immediately available to the flight crew whenever navigation is predicated on the use of the system. The Operational Revision Status (ORS) of the Pilot's Guide must match the ORS level annunciated on the Self Test page.
- B. Navigation is prohibited within 60 n.m. of the north and south poles (i.e. at greater than 89° north and south latitudes).
- C. IFR Navigation is restricted as follows:
 - 1. The system must utilize ORS level 01 or later FAA approved revision.
 - 2. The data on the self test page must be verified prior to use.
 - 3. IFR en route and terminal navigation is prohibited unless the pilot verifies the currency of the aeronautical data base or verifies each selected waypoint for accuracy by reference to current approved data.
 - 4. Instrument approaches must be accomplished in accordance with approved instrument approach procedures that are retrieved from the KLN 94 data base. The KLN 94 aeronautical data base must incorporate the current update cycle.
 - (a) The KLN 94 Quick Reference, P/N 006-18228-0000, Rev. 1 dated 8/2000 (or later applicable revision) must be immediately available to the flight crew during instrument approach operations.
 - (b) Instrument approaches must be conducted in the approach mode and RAIM must be available at the Final Approach Fix.
 - (c) APR ACTV mode must be annunciated at the Final Approach Fix.

- (d) Accomplishment of ILS, LOC, LOC-BC, LDA, SDF, and MLS approaches are not authorized.
 - (e) When an alternate airport is required by the applicable operating rules, it must be served by an approach based on other than GPS or Loran-C navigation.
 - (f) The KLN 94 can only be used for approach guidance if the reference coordinate datum system for the instrument approach is WGS-84 or NAD-83. (All approaches in the KLN 94 data base use the WGS-84 or the NAD-83 geodetic datums.)
5. For BRNAV operations in the European region:
- (a) With 23 (24 if the altitude input to the KLN 94 is not available) or more satellites projected to be operational for the flight, the aircraft can depart without further action.
 - (b) With 22 (23 if the altitude input to the KLN 94 is not available) or fewer satellites projected to be operational for the flight, the availability of the GPS integrity (RAIM) should be confirmed for the intended flight (route and time). This should be obtained from a prediction program run outside the aircraft. The prediction program must comply with the criteria of appendix 1 of AC90-96. In the event of a predicted continuous loss of RAIM of more than 5 minutes for any part of the intended flight, the flight should be delayed, cancelled, or rerouted on a track where RAIM requirements can be met.

NOTE: Honeywell's Preflight, Version 2.0 or later computer based prediction program may be used for the RAIM prediction. Alternate methods should be submitted for approval in

accordance with Advisory Circular
AC90-96.

6. The aircraft must have other approved navigation equipment appropriate to the route of flight installed and operational.

SECTION III - EMERGENCY PROCEDURES

- A. If the KLN 94 GPS information is not available or invalid, utilize remaining operational navigation equipment as required.
- B. If a “RAIM NOT AVAILABLE” message is displayed while conducting an instrument approach, terminate the approach. Execute a missed approach if required.
- C. If a “RAIM NOT AVAILABLE” message is displayed in the en route or terminal phase of flight, continue to navigate using the KLN 94 or revert to an alternate means of navigation appropriate to the route and phase of flight. When continuing to use GPS navigation, position must be verified every 15 minutes using another IFR approved navigation system.
- D. Refer to the KLN 94 Pilot’s Guide, Appendices B and C, for appropriate pilot actions to be accomplished in response to annunciated messages.

SECTION IV - NORMAL PROCEDURES

A. OPERATION

Normal operating procedures are outlined in the KLN 94 GPS Pilot's Guide, P/N 006-18207-0000, dated September, 2000 (or later applicable revision). A KLN 94 Quick Reference, P/N 006-18228-0000 Rev. 1 dated 8/2000 (or later applicable revision) containing an approach sequence, operating tips and approach related messages is intended for cockpit use by the pilot familiar with KLN 94 operations when conducting instrument approaches.

B. SYSTEM ANNUNCIATORS/SWITCHES/CONTROLS

1. HSI NAV presentation (**NAV/GPS**) switch annunciator - May be used to select data for presentation on the pilot's HSI; either NAV data from the number one navigation receiver or GPS data from the KLN 94 GPS. Presentation on the HSI is also required for autopilot coupling.
2. Message (**MSG**) annunciator - Will flash (along with a large "M" on the right side of the KLN 94 screen) to alert the pilot of a situation that requires attention. Press the MSG button on the KLN 94 GPS to view the message. If a message condition exists which requires a specific action by the pilot, the message annunciator will remain on but will not flash. (Appendix B of the KLN 94 Pilot's Guide contains a list of all of the message page messages and their meanings).

3. Waypoint (**WPT**) annunciator - Prior to reaching a waypoint in the active flight plan, the KLN 94 GPS will provide navigation along a curved path segment to ensure a smooth transition between two adjacent legs in the flight plan. This feature is called turn anticipation. Approximately 20 seconds prior to the beginning of turn anticipation the WPT annunciator (along with a large “WPT” on the right side of the KLN 94 screen) will flash, going solid upon initialization of the turn, and extinguishing upon turn completion..

WARNING: Turn anticipation is automatically disabled for FAF waypoints and those used exclusively in PD/STARS where overflight is required. For waypoints shared between PD/STARS and published en route segments (requiring overflight in the PD/STARS), proper selection on the presented waypoint page is necessary to provide adequate route protection on the PD/STARS.

4. HSI course control  knob - Provides analog course input to the KLN 94 in **OBS** when the NAV/GPS switch/annunciator is in **GPS**. When the NAV/GPS switch annunciation is in **NAV**, GPS course selection in **OBS** mode is digital through the use of the controls and display at the KLN 94. The HSI course control knob must also be set to provide proper course datum to the autopilot if coupled to the KLN 94 in LEG or OBS.

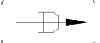
NOTE: Manual HSI course centering in **OBS** using the control knob can be difficult, especially at long distances. Centering the D-bar can best be accomplished by pressing  and then manually setting the HSI pointer to the course value prescribed in the KLN 94 displayed message

5. GPS remote approach (**GPS APR ARM/ACTV**) switch/annunciator - Used to manually select or deselect approach **ARM** (or deselect approach **ACTV**). The remote switch annunciator also annunciates the stage of approach operation; either armed (**ARM**) or activated (**ACTV**). Sequential button pushes if in **ACTV** would first result in approach **ARM** and then approach arm canceled. Subsequent button pushes will cycle between the armed state (if an approach is in the flight plan) and approach arm canceled. Approach **ACTV** cannot be selected manually.

C. PILOT'S DISPLAY

Left/right steering information is presented on the pilot's HSI as a function of the NAV/GPS switch position.

D. AUTOPILOT COUPLED OPERATION

The KLN 94 may be coupled to the autopilot by first selecting **GPS** on the NAV/GPS switch. Manual selection of the desired track on the pilot's HSI course pointer is required to provide course datum to the autopilot. (Frequent manual course pointer changes may be necessary, such as in the case of flying a DME arc.) The autopilot approach mode (**APR**) should be used when conducting a coupled GPS approach.

NOTE: NAV or APR coupled DME arc intercepts can result in excessive overshoots (aggravated by high ground speeds and/or intercepts from inside the arc).

E. APPROACH MODE SEQUENCING AND RAIM PREDICTION

WARNING: Familiarity with the en route operation of the KLN 94 does not constitute proficiency in approach operations. Do not attempt approach operations in IMC prior to attaining proficiency in the use of the KLN 94.

NOTE: The special use airspace alert will automatically be disabled prior to flying an instrument approach to reduce the potential for message congestion.

1. Prior to arrival, select a STAR if appropriate from the **APT 7** page. Select an approach and an initial approach fix (IAF) from the **APT 8** page. The most efficient means of getting to these pages is initiated by pressing the **PROC** button on the KLN 94.
 - a. Press **PROC** button.
 - b. Select Approach, Arrival, or Departure.
 - c. Select the Airport from the list or enter the desired Airport identifier.

- d. The **APT 7** or **APT 8** page will be displayed as appropriate.

NOTE: To delete or replace a DP, STAR or approach, select **FPL 0** page. Place the cursor over the name of the procedure, press **ENT** to change it, or **CLR** then **ENT** to delete it.

2. En route, check for RAIM availability at the destination airport ETA on the **AUX 3** page.

NOTE: RAIM must be available at the FAF in order to fly an instrument approach. Be prepared to terminate the approach upon loss of RAIM.

3. At or within 30 nm from the airport:
 - a. Verify automatic annunciation of APR **ARM**.
 - b. Note automatic d-bar scaling change from $\pm 5.0\text{nm}$ to $\pm 1.0\text{ nm}$ over the next 30 seconds.
 - c. Update the KLN 94 altimeter baro setting as required.
 - d. Internally the KLN 94 will transition from en route to terminal integrity monitoring.
4. Select **NAV 4** page to fly the approach procedure.
 - a. If there is a need to fly a procedure turn or holding pattern, fly in OBS until inbound to the FAF.

- NOTE:** OBS navigation is TO-FROM (like a VOR) without waypoint sequencing.
- b. If receiving radar vectors, choose **VECTORS** as the IAF, activate vectors when the first vector for the approach is received, and leave the unit in **LEG** mode.
 - c. **NoPT** routes including DME arc's are flown in **LEG**. **LEG** is mandatory from the FAF to the MAP.

NOTE: NAV or APR coupled DME arc intercepts can result in excessive overshoots (aggravated by high ground speeds and/or intercepts from inside the arc).

WARNING: Flying final outbound from an off-airport vortac on an overlay approach; beware of the DME distance increasing on final approach, and the GPS distance-to-waypoint decreasing, and not matching the numbers on the approach plate.

- 5. At or before 2 nm from the FAF inbound:
 - a. Select the FAF as the active waypoint, if not accomplished already.
 - b. Select LEG operation.

6. Approaching the FAF inbound (within 2 nm.):
 - a. Verify APR **ACTV**.
 - b. Note automatic dbar scaling change from ± 1.0 nm to ± 0.3 nm over the 2 nm inbound to the FAF.
 - c. Internally the KLN 94 will transition from terminal to approach integrity monitoring.
7. Crossing the FAF and APR **ACTV** is not annunciated:
 - a. Do not descend.
 - b. Execute the missed approach.
8. Missed Approach:
 - a. Climb
 - b. Navigate to the MAP (in APR **ARM** if APR **ACTV** is not available).

NOTE: There is no automatic **LEG** sequencing at the MAP.

- c. After climbing in accordance with the published missed approach procedure, press , verify or change the desired holding fix and press **ENT**.

GENERAL NOTES

- The aeronautical data base must be up to date for instrument approach operation.
- Only one approach can be in the flight plan at a time.

- Checking RAIM prediction for your approach while en route using the **AUX 3** page is recommended. A self check occurs automatically within 2nm of the FAF. APR **ACTV** is inhibited without RAIM.
- Data cannot be altered, added to or deleted from the approach procedures contained in the data base. (DME arc intercepts may be relocated along the arc through the **NAV 4** or the **FPL 0** pages).
- **Some approach waypoints do not appear on the approach plates (including in some instances the FAF).**
- Waypoint suffixes in the flight plan:
 - i – IAF
 - f – FAF
 - m – MAP
 - h - missed approach holding fix

- The DME arc IAF (arc intercept waypoint) will be a) on your present position radial off the arc VOR when you load the IAF into the flight plan, or b) the beginning of the arc if currently on a radial beyond the arc limit. To adjust the arc intercept to be compatible with a current radar vector, bring up the arc IAF waypoint in the **NAV 4** page scanning field or under the cursor on the **FPL 0** page, press **CLR**, then **ENT**. Fly the arc in LEG. Adjust the HSI or CDI course pointer with reference to the desired track value on the **NAV 4** page (it will flash to remind you). Left/right dbar information is relative to the arc. Displayed distance is not along the arc but direct to the active waypoint. (The **ARC** radial is also displayed in the lower right corner of the **NAV 4** page).
- The DME arc IAF identifier may be unfamiliar. Example: D098G where 098 stands for the 098° radial off the referenced VOR, and G is the seventh letter in the alphabet indicating a 7 DME arc.
- APR **ARM** to APR **ACTV** is automatic provided:

- a. You are in APR **ARM** (normally automatic).
 - b. You are in **LEG** mode.
 - c. The **FAF** is the active waypoint.
 - d. Within 2 n.m. of the FAF.
 - e. Outside of the FAF.
 - f. Inbound to the FAF.
 - g. RAIM is available.
- Direct-To operation between the FAF and MAP cancels APR **ACTV**. Fly the missed approach in APR **ARM**.
 - Flagged navigation inside the FAF may automatically bring up the message page stating:

PRESS **PROC** BUTTON NOW FOR NAVIGATION

Pressing the **PROC** button may usually restore navigation (not guaranteed) by changing from **APR ACTV** to **APR ARM**. Fly the missed approach.

- The instrument approach using the KLN 94 may be essentially automatic starting 30 nm out (with a manual baro setting update) or it may require judicious selection of the OBS and LEG modes.

SECTION 5 - PERFORMANCE

No Change.

APPENDIX C
SUPPLEMENTAL TYPE CERTIFICATE

THIS PAGE IS RESERVED

United States of America
Department of Transportation -- Federal Aviation Administration
Supplemental Type Certificate

Number SA00909WI-D

This certificate issued to

Honeywell International Inc.
23500 W. 105th Street
Olathe, KS 66061

certifies that the change in the type design for the following product with the limitations and conditions therefor as specified hereon meets the airworthiness requirements of Part 3 of the Civil Air Regulations and additional requirements as specified in TCDS 3A16.

Original Product - Type Certificate Number: 3A16
Make: Beech
Model: 95-55, 95-A55, 95-B55, 95-B55A, 95-B55B, 95-C55, 95-C55A, D55, E55, E55A

Description of Type Design Change:

Installation of the Bendix/King KLN 94 GPS (Global Positioning System) Navigation Receiver for IFR enroute and non-precision approach operations.

REQUIRED DATA: 1. Master Drawing List 159-08254-0001, Revision C, dated 10-13-00 and 2. Airplane Flight Manual Supplement 006-00877-0000, Revision 0, dated 11-1-2000.

Later FAA approved revisions to the above listed data are incorporated without further revision to this Supplemental Type Certificate.

Limitations and Conditions:

1. This approval should not be extended to other specific airplanes of this model on which other previously approved modifications are incorporated, unless it is determined that the interrelationship between this change and any of those other previously approved modifications will introduce no adverse effect upon the airworthiness of that airplane.

(Continued on Continuation Sheet)

If the holder agrees to permit another person to use this certificate to alter the product, the holder shall give the other person written evidence of that permission.

This certificate and the supporting data which is the basis for approval shall remain in effect until surrendered, suspended, revoked or a termination date is otherwise established by the Administrator of the Federal Aviation Administration.

Date of application: 1-31-2000

Date reissued:

Date of issuance: 11-1-2000

Date amended:



By direction of the Administrator

Chris Durkin

(Signature)

Chris Durkin
DAS Coordinator, DAS-500863-CE

(Title)

Any alteration of this certificate is punishable by a fine of not exceeding \$1,000, or imprisonment not exceeding 3 years, or both.

FAA FORM 8110-2(10-68) PAGE 1 of 3 PAGES

This certificate may be transferred in accordance with FAR 21.47.

INSTRUCTIONS: The transfer endorsement below may be used to notify the appropriate FAA Regional Office of the transfer of this Supplemental Type Certificate.

The FAA will reissue the certificate in the name of the transferee and forward it to him.

TRANSFER ENDORSEMENT

Transfer the ownership of Supplemental Type Certificate Number _____

to *(Name of transferee)* _____

(Address of transferee) _____
(Number and street)

(City, State, and ZIP code)

from *(Name of grantor) (Print or type)* _____

(Address of grantor) _____
(Number and street)

(City, State, and ZIP code)

Extent of Authority (if licensing agreement): _____

Date of Transfer: _____

Signature of grantor *(In ink)*: _____

United States of America
Department of Transportation -- Federal Aviation Administration
Supplemental Type Certificate
(Continuation Sheet)

Number SA00909WI-D

Limitations and Conditions: (continued)

2. The KLN 94 GPS has been evaluated as a navigation input source for the KAP 140 and KFC 225 Automatic Flight Control Systems and found to be compatible; the interface of these systems are approved.
3. Additional equipment required for the specific type of operation must be installed and operational prior to use the KLN 94 under Instrument Flight Rules (IFR).

Any alteration of this certificate is punishable by a fine of not exceeding \$1,000, or imprisonment not exceeding 3 years, or both.

THIS PAGE IS RESERVED.

APPENDIX D
DIRECT REPLACEMENT OF A KLN 89B WITH A KLN 94

THIS PAGE IS RESERVED.

If the aircraft is equipped with a Bendix/King KLN 89B GPS receiver, the KLN 89B unit can be removed and a KLN 94 unit installed. No changes to the existing mounting rack or electrical harness are required. However, if the KLN 89B is configured only for IFR Enroute operations, the KLN 94 must be configured the same way.

The KLN 94 also has additional features, such as QuickTune™, which may be added. When the KLN 94 additional features are utilized in existing KLN 89B installations, wiring harness changes will be necessary. See the KLN 94 wiring diagrams in this book.

Once the KLN 94 has been installed, a post installation checkout procedure must be performed. Also see the KLN 89B / KLN 94 substitution letter following this page.

THIS PAGE IS RESERVED.

APPENDIX E
ENVIRONMENTAL QUALIFICATION FORMS

THIS PAGE IS RESERVED.

RTCA/DO 160D

ENVIRONMENTAL QUALIFICATION FORM

NOMENCLATURE: KLN 94 GPS/LNAV
 PART NUMBER: 069-01034-0101 GPS/LNAV
 069-01034-0102 GPS/LNAV
 050-03321-0000 INSTALLATION KIT
 TSO NUMBER: C129a Class A1
 MANUFACTURER'S SPECIFICATION: MPS 004-02179-4000
 MANUFACTURER: HONEYWELL INTERNATIONAL INC.
 ADDRESS: ONE TECHNOLOGY CENTER
 23500 W. 105TH STREET
 OLATHE, KS 66061 USA

Conditions	DO-160D Section	Category	Description
Temperature and Altitude	4.0	A1F1	
Low Temperature	4.5.1		Low Temperature, -20 °C (See Note 3)
High Temperature	4.5.2 / 4.5.3		High Temperature, +55 °C
Altitude	4.6.1		Altitude, 55,000 feet
Decompression	4.6.2		Decomp., to 55K feet in < 15 secs
Overpressure	4.6.3		Overpressure, 170 kPa
In-Flight Loss of Cooling	4.5.4	V	Loss of Cooling, 30 mins minimum
Temperature Variation	5.0	B	5 °C / minute
Humidity	6.0	A	standard
Operational Shocks and Crash Safety	7.0	B	
Vibration	8.0	S2	Fixed wing; zone is instrument panel, console, and equipment rack. (See Notes 1 and 2)
Explosion Proofness	9.0	X	not required
Waterproofness	10.0	X	not required
Fluids Susceptibility	11.0	X	not required
Sand and Dust	12.0	X	not required
Fungus	13.0	X	not required
Salt Spray	14.0	X	not required
Magnetic Effect	15.0	Z	compass deflects 1 degree at less than 0.3 m

RTCA/DO 160D

ENVIRONMENTAL QUALIFICATION FORM

Power Input	16.0	BZ	
Voltage Spike	17.0	A	
Audio Frequency Conducted Susceptibility	18.0	BZ	
Induced Signal Susceptibility	19.0	A	
Radio Frequency Susceptibility	20.0	R	(See Note 4)
Emission Of Radio Frequency Energy	21.0	M	
Lightning Induced Transient Susceptibility	22.0	A3E3	(See Note 6)
Lightning Direct Effects	23.0	1B	
Icing	24.0	X	not required
ESD	25.0	A	No damage. Experienced functional upset (See Note 5).

Notes:

1. Vibration Critical Frequencies:

The following critical frequencies are mechanical resonances of the unit under test that have peak acceleration amplitudes greater than twice the input acceleration amplitude:

Vertical, Hz (Z axis)	Longitudinal, Hz (X axis)	Lateral, Hz (Y axis)
192-202	265-456	290-398
397-429		299-424
471-499		596-612
574-597		646-670
801-867		
924-1058		
1895-1983		

2. Vibration – Additional Testing

The KLN 94 passed when subjected to DO-160D sinusoidal test curve M, DO-160D random test curve B, and DO-160C Helicopter test curves Y and N.

3. Temperature– Additional Testing

The KLN 94 performance was recorded at additional low temperatures. At –35 °C, immediately after power-up, the display was unreadable. After a 15 minute warm up, the display was readable.

RTCA/DO 160D

ENVIRONMENTAL QUALIFICATION FORM

4. Radio Frequency Susceptibility – Additional Testing

For each frequency listed, the KLN 94 was radiated with a long-term (greater than 10 seconds) continuous wave (CW) signal. The amplitude where the KLN 94's satellite reception began to be affected is shown. The amplitude where the KLN 94's satellite reception was lost is also shown.

Frequency, MHz	Amplitude where reception affected, V/m	Amplitude where reception lost, V/m
1205	0.25	1.0
1208	1.0	5.0
1213.5	30	Not Lost
1575.42	0.125	0.5

5. ESD Functional Upset

Repeated application of electrostatic pulse directly to display causes loss of display requiring operator intervention. No permanent damage caused by ESD test.

6. Lightning Induced Transient Susceptibility – Additional Testing

Cable bundle testing was conducted using the multiple stroke waveform sets of the SAE AE4L Committee Report AE4L-97-4 (Purple Book).

REVISION HISTORY

Revision	PRN/CO	By	Date	Description of Change
-	173950	M. Williams	Sep 2000	Initial Release
A	721124	A. Morozov	Nov 2002	Added 069-01034-0102 (Roll Steering) flavor

THIS PAGE IS RESERVED

RTCA/DO-160C
ENVIRONMENTAL QUALIFICATION FORM

NOMENCLATURE: KA 92 ANTENNA
 PART NUMBER: 071-01553-0200
 TSO NUMBER: C129
 MANUFACTURER'S SPECIFICATION: See Specification Control Dwg.
 071-01553-0200
 MANUFACTURER: ALLIEDSIGNAL GENERAL AVIATION AVIONCS
 ADDRESS: 400 N. ROGERS ROAD
 OLATHE, KS 66062
 USA

CONDITIONS	PARA	CONDUCTED TESTS
TEMPERATURE AND ALTITUDE	4.0	Category A2 and F2
TEMPERATURE VARIATION	5.0	Category A
HUMIDITY	6.0	Category C
SHOCK	7.0	Operational Shock Test
VIBRATION	8.0	Categories C, L, M and Y
EXPLOSION	9.0	Category X (NOT TESTED)
WATERPROOFNESS	10.0	Category R
FLUIDS SUSCEPTIBILITY	11.0	Category F
SAND AND DUST	12.0	Category X (Not Tested)
FUNGUS	13.0	Category X (Not Tested)
SALT SPRAY	14.0	Category S
MAGNETIC EFFECT	15.0	Class Z
POWER INPUT	16.0	Category A and B
VOLTAGE SPIKE CONDUCTED	17.0	Category A and B
AUDIO FREQUENCY CONDUCTED SUSCEPTIBILITY	18.0	Category A, B and Z
INDUCED SIGNAL SUSCEPTIBILITY	19.0	Category A
RADIO FREQUENCY SUSCEPTIBILITY	20.0 Change 3	Category R
RADIO FREQUENCY EMISSION	21.0 Change 3	Category A
LIGHTING INDUCED TRANSIENT SUSCEPTIBILITY	22.0 Change 2	Category XXE3
LIGHTING DIRECT EFFECTS	23.0 Change 1	Category 1B
ICING	24.0	Category C

RTCA/DO-160C
ENVIROMENTAL QUALIFICATION FORM
REVISION HISTORY

REV NUMBER	ECO NUMBER	DATE
0	ORIGINAL ISSUE	DECEMBER 1994
1	102111	JANUARY 1995

REMARKS

-Fluids Susceptability

Fluids Used:

Ethylene Glycol
Isopropyl Alcohol
Denatured Alcohol
1,1,1 Trichloroethane
Jet A Fuel
Aviation Fuel
Skydrol, Type IV
Dichlorvos (DDVP)
Pyrethrum - Based Inseticide
AEA Type 1
AEA Type 2

Swelling of KA 92 observed when exposed to Dichlorvos (DDVP).

THIS PAGE IS RESERVED.

RTCA/DO-160C
ENVIRONMENTAL QUALIFICATION FORM

NOMENCLATURE: KA 91 GPS ANTENNA
 PART NUMBER: 071-01545-0100/0200
 TSO NUMBER: NOT AVAILABLE for 0100,
 C129 for 0200
 MANUFACTURER'S SPECIFICATION: See Specification Control Dwg.
 071-01545-0100
 MANUFACTURER: KING RADIO CORPORATION
 ADDRESS: 400 N. ROGERS
 OLATHE, KS 66062
 USA

CONDITIONS	PARA	CONDUCTED TESTS
TEMPERATURE AND ALTITUDE	4.0	CATEGORY A2 and F2
TEMPERATURE VARIATION	5.0	CATEGORY A
HUMIDITY	6.0	CATEGORY C
SHOCK	7.0	PER SHOCK TEST
VIBRATION	8.0	CATEGORIES C,L,M, and Y
EXPLOSION	9.0	CATEGORY X (NOT TESTED)
WATERPROOFNESS	10.0	CATEGORY R
FLUIDS SUSCEPTIBILITY	11.0	CATEGORY F
SAND AND DUST	12.0	CATEGORY X (NOT TESTED)
FUNGUS	13.0	CATEGORY X (NOT TESTED)
SALT SPRAY	14.0	CATEGORY S
MAGNETIC EFFECT	15.0	CLASS A
POWER INPUT	16.0	CATEGORY X (NOT TESTED)
VOLTAGE SPIKE CONDUCTED	17.0	CATEGORY A & B
AUDIO FREQUENCY CONDUCTED SUSCEPTIBILITY	18.0	CATEGORY B & Z
INDUCED SIGNAL SUSCEPTIBILITY	19.0	CATEGORY A
RADIO FREQUENCY SUSCEPTIBILITY	20.0	CATEGORY U *
RADIO FREQUENCY EMISSION	21.0	CATEGORY A
LIGHTNING INDUCED TRANSIENT SUSCEPTIBILITY	22.0	CATEGORY L
LIGHTNING DIRECT EFFECTS	23.0	CATEGORY 1B
ICING	24.0	CATEGORY C

* Additional HIRF testing conducted, see test report 707-00615-0000

RTCA DO-160
ENVIRONMENTAL QUALIFICATION FORM
REVISION HISTORY

REVISION	CHANGE ORDER NO.	DATE
1	ECO 98584	July 1993



U.S. Department
of Transportation
**Federal Aviation
Administration**
October 31, 2000

Small Airplane Directorate
Wichita Aircraft Certification Office
1801 Airport Road, Room 100
Wichita, Kansas 67209

Robert Murray
Assistant DAS Coordinator
Honeywell International Inc.
One Technology Center
23500 W. 105th Street
Olathe, KS 66061

Subject: Bendix/King KLN 94 GPS Receiver as a direct substitute for the Bendix/King
KLN 89B GPS Receiver

Dear Mr. Murray:

The FAA Wichita Aircraft Certification Office has evaluated Honeywell's proposal to substantiate that the KLN 94 is a direct replacement for an approved KLN 89B. Based on the test data provided, the FAA Wichita Aircraft Certification Office concurs that the entire process detailed in AC 20-138 should not be necessary for this replacement based on the similarity of the KLN 94 and the KLN 89B.

The installer should follow the guidelines below. If these guidelines cannot be followed, AC 20-138 should then be referenced for the approval process.

1. The KLN 94, to be considered a replacement, must be installed in the existing KLN 89B location.
2. If the KLN 89B was originally approved for VFR use only, the KLN 94 may be approved for VFR use only (If IFR approval is desired, a new installation approval must be requested from and granted by the local Flight Standards Office).
3. If the KLN 89B was originally approved for IFR use, the KLN 94 may be approved for IFR use.
4. Operational checks must be conducted per the current revision of the KLN 94 installation manual.
5. A KLN 94 flight manual supplement must be created, FAA approved, and installed in the pilot's operating handbook.
6. Any additional changes to the existing installation (such as adding "quick tune" wiring) must be subjected to an approval process which is appropriate for the magnitude of the change.

7. Local Flight Standards Office approval is necessary for the KLN 94 installation.

Sincerely,

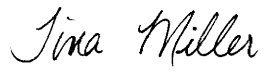
A handwritten signature in cursive script that reads "Tina Miller".

Tina Miller
Program Manager
Wichita Aircraft Certification Office