

General Aviation Bearings Interchange Guide

Bearings to sizes and configurations as commonly, but not exclusively, used in the General Aviation industry. Dimensions and materials are used to aid in comparison. Table to be used as a reference guide. Ultimately, interchange should be determined by comparing relevant manufacturers specifications and dimensions.

Male Thread Bearings

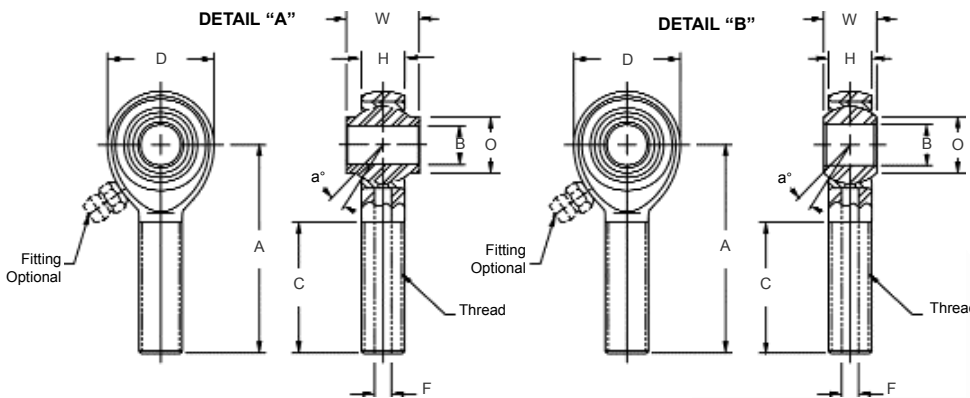

Specifications	
BODY	Low Carbon Steel, Protective Coated for Corrosion Resistance.
BALL	Alloy steel, Heat treated, Hard Chrome Plated (QQ-C-320, Class 2).
RACE	Low Carbon Steel, Protective Coated for Corrosion Resistance.

Units are traceable and magnetic particle inspected after assembly.

Load ratings apply only to rod ends without grease fittings. For load ratings with fittings, please contact our engineering department.

Rod End No.		DIMENSIONS IN INCHES											a°	Ultimate	Approx.
AURORA Part No.	Heim Part No.	Ball Shoulder Configuration	B +.0015 -.0005	W + .000 - .005	H ±.005	A ±.015	D ±.010	Shoulder Dia. Ref.	Ball Dia. Ref.	C Min.	F Drilled Hole Dia Ref.	Thread UNF-3A	Misalign. Angle	Radial Static Load Capacity	Brg. Wt. Lbs.
GMM-3M-470	M34-14M	See Detail "A"	.1900	.437	.281	1.562	.750	.315	.500	.969	-	1/4-28	17	2,158	.05
GMM-3M-570	MD35-14M	See Detail "A"	.1900	.437	.328	1.375	.875	.315	.500	.750	.113	5/16-24	10	2,823	.07
GMM-3M-670	MD36-14M	See Detail "A"	.1900	.437	.328	1.375	.750	.315	.500	.750	.113	3/8-24	10	2,850	.08
GMM-3M-680	MD36-16M	See Detail "B"	.1900	.500	.375	1.812	.833	.319	.593	1.062	.136	3/8-24	18	3,269	.09
GMM-4M-470	M44-14M	See Detail "B"	.2500	.437	.304	1.562	.812	.353	.562	.969	-	1/4-28	18	2,158	.07
GMM-4M-675	MD46-15M	See Detail "B"	.2500	.484	.335	2.312	.875	.395	.625	1.500	.136	3/8-24	18	3,160	.11
GMM-4M-680	MD46-16M	See Detail "B"	.2500	.500	.335	2.062	.875	.375	.625	1.500	.159	3/8-24	21	2,985	.10

Units are supplied without grease fittings. When grease fittings are required, specify by adding suffixes as designated.

Z Zerk type fitting

Ex: GMM-3MZ-470

F Flush type fitting

Ex: GMM-3MF-470

For left hand thread use the letter "B" in the prefix Ex: GMB-3M-470

Female Thread Bearings

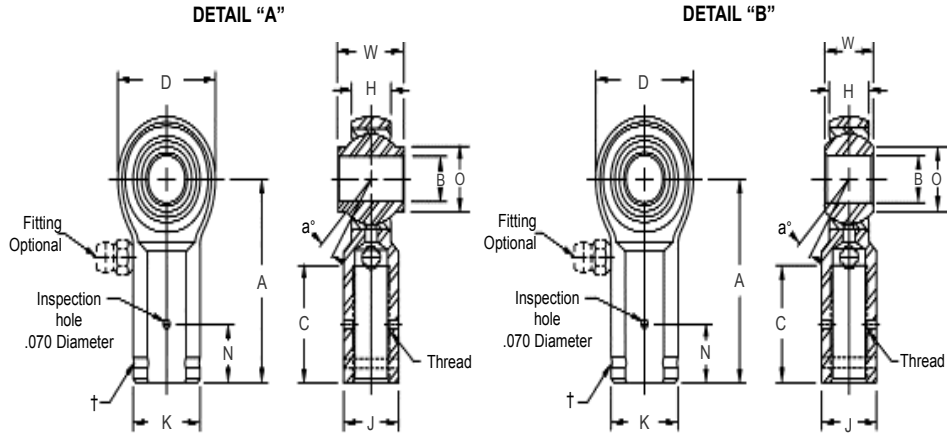

† Left hand units identification groove near end of shank

Load ratings apply only to rod ends without grease fittings. For load ratings with fittings, please contact our engineering department.

Rod End No.		DIMENSIONS IN INCHES											a° Misalign. Angle	Ultimate Radial Static Load Capacity	Approx. Brg. Wt. Lbs.		
AURORA Part No.	Heim Part No.	Ball Shoulder Configuration	B +.0015 - .0005	W +.000 - .005	H ±.005	A ±.015	D ±.010	K ±.010	J ±.010	N ±.005	O Shoulder Dia. Ref.	C Ball Dia. Ref.				Thread UNF-3B	
GMW-3M-470	F34-14M	See Detail "A"	.1900	.437	.328	1.375	.750	.468	.375	.312	.315	.500	.750	1/4-28	10	2,881	.06
GMW-3M-471	F347-14M	See Detail "A"	.1900	.437	.328	1.062	.750	.375	-	-	.315	.500	.437	1/4-28	10	2,881	.05
GMW-3M-480	F34-16M	See Detail "A"	.1900	.500	.375	1.375	.812	.468	.375	.312	.312	.562	.750	1/4-28	15	3,152	.08
GMW-3M-570	F35-14M	See Detail "A"	.1900	.437	.328	1.375	.750	.500	.437	.312	.315	.500	.750	5/16-24	10	2,881	.07
GMW-4M-470	F44-14M	See Detail "B"	.2500	.437	.304	1.375	.812	.468	.437	.312	.353	.562	.750	1/4-28	18	2,950	.08
GMW-4M-595	F45-19M	See Detail "A"	.2500	.593	.406	1.469	.938	.500	-	.312	.485	.687	.844	5/16-24	10	3,359	.10

Units are supplied without grease fittings. When grease fittings are required, specify by adding suffixes as designated.

Z Zerk type fitting

Ex: GMW-3MZ-470

F Flush type fitting

Ex: GMW-3MF-470

For left hand thread use the letter "G" in the prefix Ex: GMG-3M-470